

FLOWSEAL

CRANE

A Crane Co. Company

INSTALLATION and MAINTENANCE INSTRUCTIONS

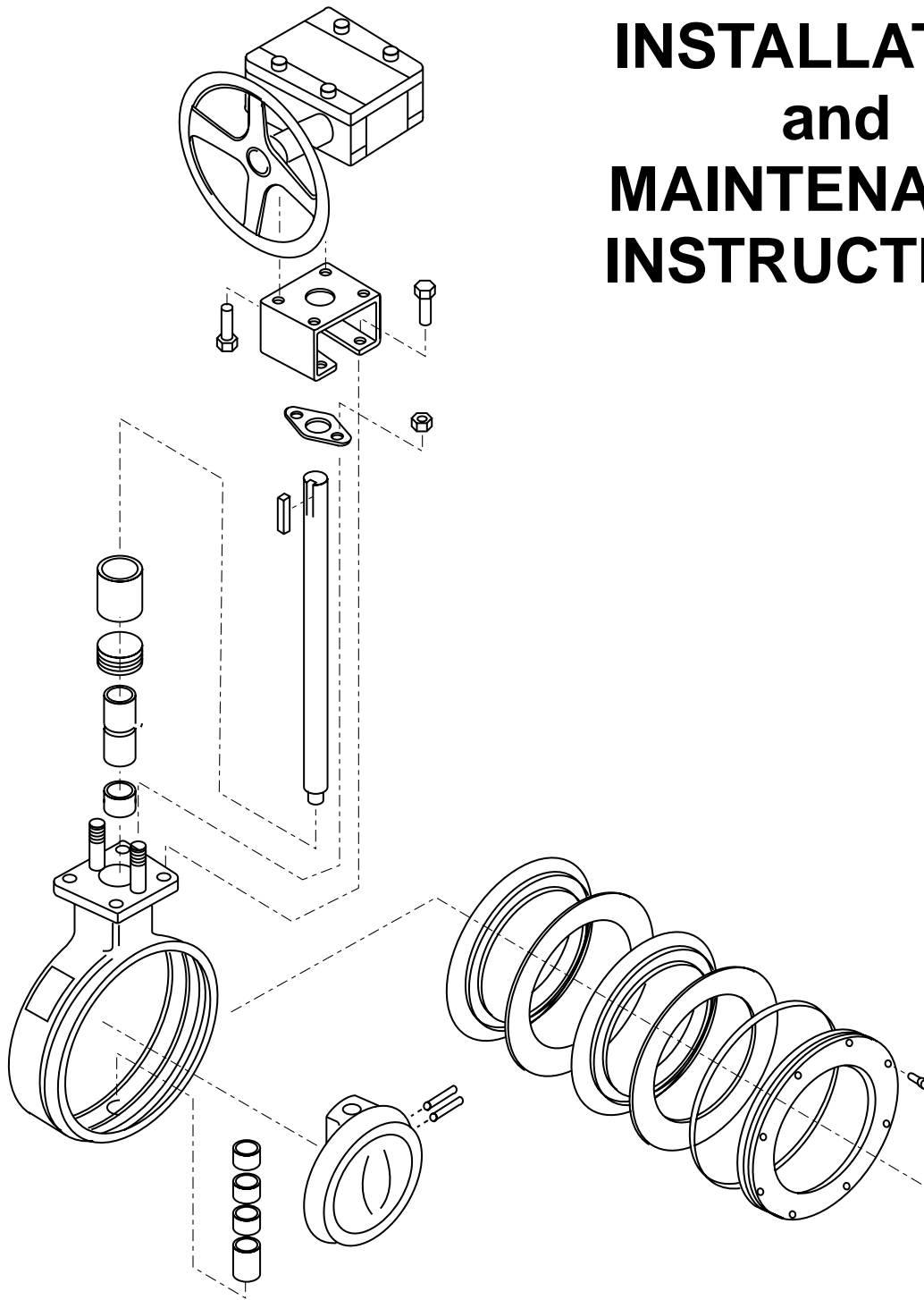

MANUAL AND AUTOMATED

HIGH PERFORMANCE BUTTERFLY VALVES

CONTENTS

Introduction

| | |
|-----------------------------------|---|
| Valve Description | 3 |
| Valve Design Features | 3 |
| Flange Compatibility | 3 |
| Gasket Compatibility | 3 |
| Pipe Schedule Compatibility | 3 |
| Product Identification | 3 |
| Operating Pressures | 3 |
| Seat Alternatives | 4 |
| Offset Disc Design | 4 |
| Seat Retainer Alternatives | 5 |

Installation Recommendations

| | |
|--|------|
| Valve Ratings | 6 |
| Seat Upstream vs Seat Downstream | 6 |
| Disc Clearances | 6 |
| Opening Rotation | 6 |
| Installation Position | 6 |
| Valve and Flange Preparation | 6 |
| Installation Tools | 6 |
| Required Bolting | 6 |
| Unpacking and Storage Instructions | 6 |
| Pre-Installation Procedure | 7 |
| Valve Installation Procedure | 7 |
| Bolting Dimensions | 8, 9 |

Maintenance Instructions

| | |
|---|------------|
| Safety Precautions | 10 |
| General Maintenance | 10 |
| Packing Replacement | 10 |
| End Cap Seal Replacement | 10 |
| Standard Soft Seat Replacement | 10, 11 |
| Fire-Flow and Metal Seat Replacement | 12 |
| Disc, Shaft and Bearing Replacement | 12 |
| Ratchet Handle Mounting Procedure | 13 |
| Manual Gear Mounting Procedure | 13 |
| Remote Actuator (Male Drive) Mounting Procedure | 13 |
| Remote Actuator (Female Drive) Mounting Procedure | 14 |
| Parts List | 15 |
| Flowseal Figure Number System | Back Cover |

INTRODUCTION

SECTION 1

Valve Description

The Flowseal High Performance Butterfly Valve (HPBV) is designed for ANSI Class 150, 300 and 600 piping systems and is available in both Wafer and Lug style body designs. The standard size range available is as follows:

| | |
|----------------------|----------------|
| ANSI Class 150 | 2" through 48" |
| ANSI Class 300 | 2" through 30" |
| ANSI Class 600 | 2" through 16" |

Valve Design Features

- Flowseal's HPBV's feature a double offset (or double eccentric) shaft design to minimize seat abrasion and lower torque. This double offset design allows the disc to lift off and "cam" away from the seat as it rotates open.
- The Flowseal valve always rotates clockwise to close (when viewed from above) and counterclockwise to open.
- The valve body has an Overtravel Stop which prevents the disc from over rotating into the wrong quadrant. This stop is not to be used as a disc position stop; if the disc contacts the Overtravel Stop, this means it has rotated beyond the seat
- The Flowseal valve is bi-directional, but the preferred installation position is with the seat in the upstream position (SUS). Note the arrow on the metal tag attached to the valve body for preferred direction of flow.

Flange Compatibility

The Flowseal valve is designed to fit between flanges as follows:

| | |
|---------------------------|-----------------|
| ANSI Class 150 | 2" through 24" |
| MSS SP-44 Class 150 | 30" through 48" |
| ANSI Class 300 | 2" through 24" |
| MSS SP-44 Class 300 | 30" |
| ANSI Class 600 | 2" through 16" |

Gasket Compatibility

The Flowseal valve is designed to accommodate the use of standard fiber gaskets (such as non-asbestos, flexible graphite, asbestos or equivalent gasket materials) of 1/16" or less, meeting the dimensional requirements of ANSI/AMSE B16.21. Thick elastomeric gaskets are not recommended. Metallic wound (Flexitallic) gaskets may be used with the wedge ring retainer configuration.

Pipe Schedule Compatibility

The Flowseal valve is designed to allow the disc edge to rotate into the open position without interference with pipe of a schedule equal to or lighter to those shown below:

| Size | ANSI 150 | ANSI 300 | ANSI 600 |
|-----------|----------|----------|----------|
| 2" – 12" | SCH 80 | SCH 80 | SCH 120 |
| 14" – 24" | SCH 40 | SCH 80 | SCH 120 |
| 30" | SCH 30 | SCH 80 | |
| 36" – 42" | STD WT | | |
| 48" | XS | | |

Product Identification

Every Flowseal valve has a metal identification tag attached to the valve body. Information on this tag includes the valve Figure Number, Size and Pressure Class, Materials of Construction, and Operating Pressures and Temperatures.

The metal tag also includes a Serial Number. This number, unique for each valve, is recorded by the Flowseal Quality Control Department along with the valve hydrostatic test results and material certification data for individual traceability and verification of every valve produced.

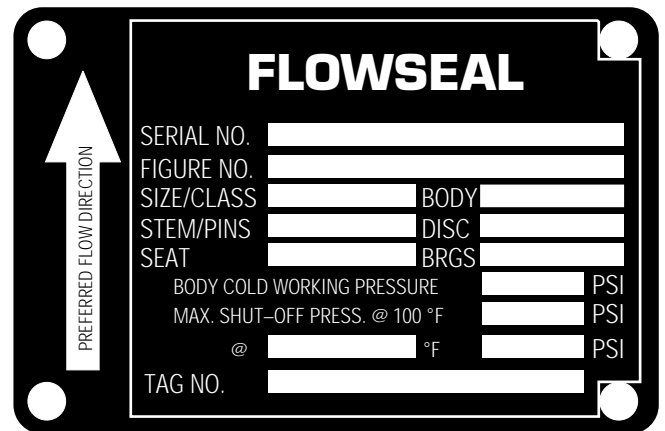

Operating Pressures

All Flowseal HPBV's may be applied to full ANSI ratings. However, different materials of construction may affect the rated pressure. The shut-off pressure rating is determined by the valve shaft and disc materials as well as the seat design, and is reflected on the metal identification tag attached to the valve.

INTRODUCTION

Seat Alternatives

Flowseal HPBV's have three seat alternatives, all of which are bi-directional.

Soft Seats provide tight shut-off to zero leakage specifications. Standard Soft Seat material includes virgin TFE or reinforced TFE (RTFE).

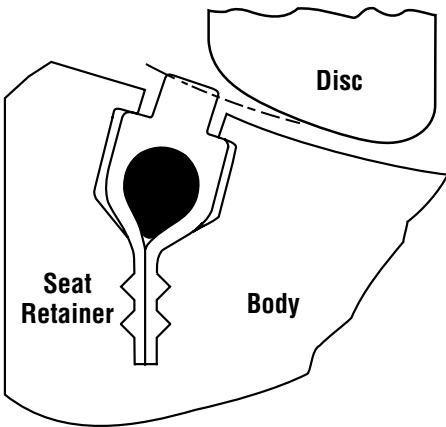

Soft Seat Profile

Fire-Flow™ Seats are designed for critical piping applications in installations such as Refinery and Petrochemical Plants. These seats are a combination of both metal and soft seats with the metal seat being designed to function during and after a fire. Valves of this type are referred to as "Fire-Safe" and are tested to meet API 607 "Fire-Safe" specifications and operation criteria.

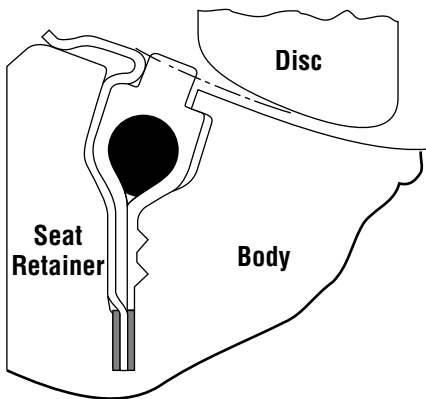

Fire-Flow™ Seat Profile

Metal Seats are well suited for higher temperature applications and provide shut-off to ANSI B16.104 Class IV.

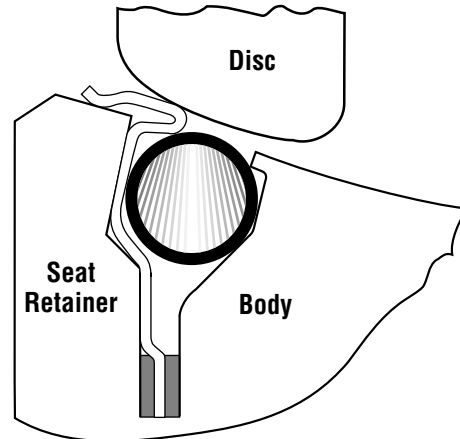

Metal Seat Profile

Offset Disc Design

All Flowseal HPBV's have both off-set discs and eccentric shafts. The off-set is applicable to the disc edge seating surface relative to the shaft center line. By off-setting the seating surface from the rotational center line, a contact with the seat is possible throughout the 360° circumference. The shaft is eccentric in the body by 0.060 inches and this enhances seat life by imparting a camming action to the disc as it rotates both in and out of the seat. Seat wear points are eliminated at the top and bottom of the disc and operating torque is reduced.

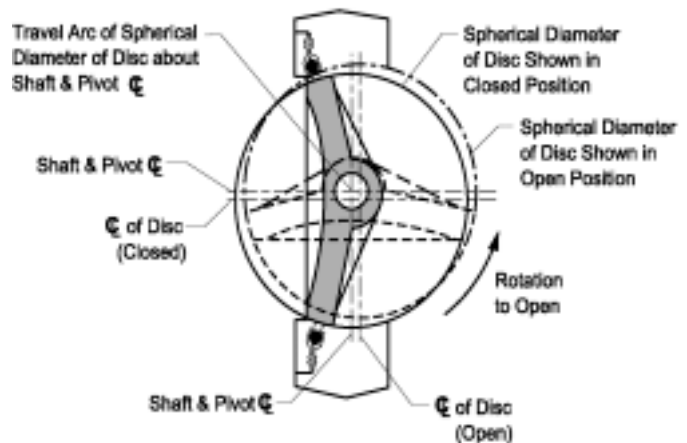

INTRODUCTION

Seat Retainer Alternatives

Flowseal HPBV's are designed to be easily maintained and, in particular, to allow rapid and simple replacement of the seat. The seat is held in the valve body by a seat retainer

which, when assembled, becomes part of the raised face flange mating surface. Two types of seat retainer fastening designs are used in Flowseal HPBFV's.

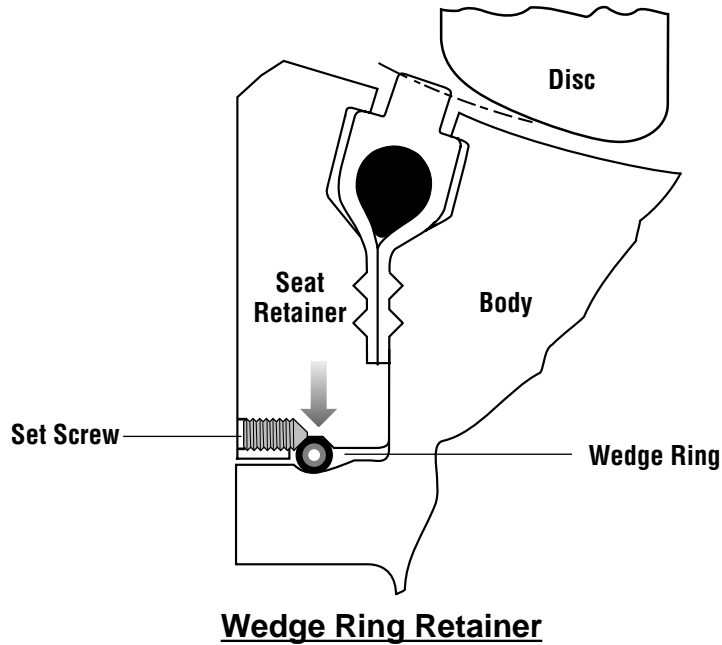

(A wedge ring is forced outward into a groove machined in the body by the insertion of set screws in the face of the retainer.)

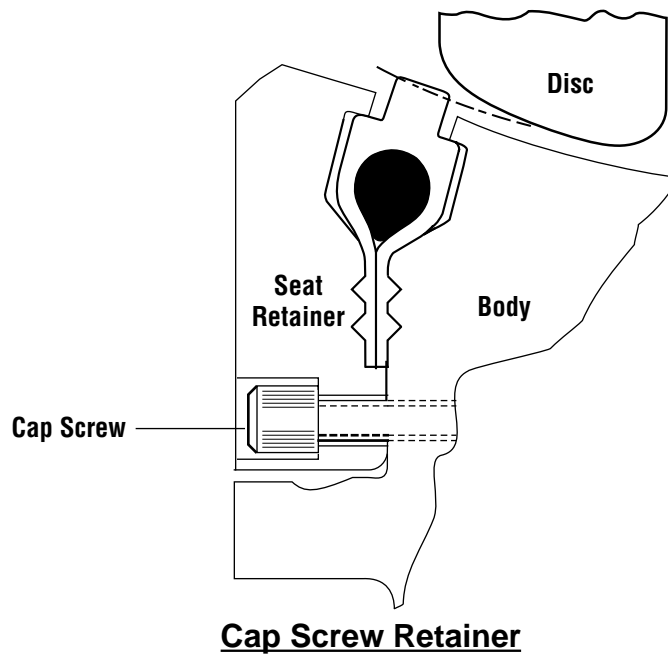

(The retainer is held to the valve body by cap screws recessed in the retainer face.)

INSTALLATION RECOMMENDATIONS

SECTION 2

Valve Ratings

Flowseal HPBV's are intended for use at the pressure and temperatures indicated on the metal nameplate attached to each individual valve. Check the valve operating temperature and pressure ratings on the valve nameplate before proceeding with installation.

Seat Upstream vs Seat Downstream

Although all Flowseal seat designs are completely bi-directional, every effort should be made to install the valve with pressure and flow from the seat side of the valve (seat upstream). Positive shutoff will be achieved with the valve in either orientation. However, installation with the seat in the upstream position will result in longer service life and lower torque valves.

Disc Clearances

Prior to installing the valve, it is important to make sure the ID of the pipe and pipe flanges is large enough to allow the disc edge to swing into the opening without interference. Damage to the disc edge can severely affect the performance of the valve. Pipe schedule compatibility for Flowseal valves is shown in Section 1 of this manual.

Opening Rotation

The Flowseal valve is designed to open with counterclockwise rotation of the shaft, and to close with clockwise rotation of the shaft when viewed from above with the shaft in the vertical position. An over-travel stop is provided in the body to prevent over-travel of the disc in the wrong direction. This stop is not to be used as a disc position stop. Contact with this stop means the disc has travelled past the seat.

Installation Position

To prevent damage during installation the valve disc must be fully closed before installing the valve in the line. It is preferable to install HPBV's with the shaft horizontal. This is important for valves applied to fluids which contain particulates. For HPBV's 16" and larger, installation should always be made with the shaft horizontal.

Valve and Flange Preparation

If the valve and mating pipe are properly prepared for installation, future problems can be avoided. All valve and pipe flange faces should be free of dirt, grit, dents, or surface irregularities which may disrupt flange sealing and cause external leakage. The valve seat and disc sealing surface should also be inspected to eliminate any dirt or foreign material that will adversely affect the operation of the valve.

Installation Tools

The only tool required in the installation of a Flowseal HPBFV is a wrench suitable for tightening the flange bolts and/or nuts required to secure the valve in-line. A hoist may be required to help manipulate valves 10" and larger. Smaller sized valves can usually be installed by hand. Temporary pipe supports may be used to keep mating flange faces parallel in order to aid in valve installation.

Required Bolting

The tables outlined on the following pages are furnished to provide information regarding the size, type, and quantity of bolting recommended for the installation of Flowseal HPBFV's. These tables are intended for use as a planning and procurement guide. All recommendations are based on pipe flanges in accordance with ANSI B16.5 for 2" through 24" valves and MSS-SP-44 for valves 30" and larger. Flange bolting is not included with the valve shipment.

Unpacking and Storage Instructions

1. Check the packing list against the valve received to verify that the size, material, and trim are correct.
2. Check to make sure that the valve and operator were not damaged during shipment.
3. When lifting the valve, take care to avoid damage to the flange faces, disc sealing edge, or operator. On larger valves, lifting holes are provided on the periphery of the valve body to aid in valve handling.
4. If the valve is to be stored before being installed, it should be protected from harsh environmental conditions.
5. Store the valve with the disc in the closed position to protect the sealing edge and the seat.
6. Keep the valve in a clean location, away from dirt, debris and corrosive materials.
7. Keep the valve in a dry area with the flange protectors attached and on a suitable skid or pallet.
8. Keep the valve in a cool location if possible, out of direct sunlight.

INSTALLATION RECOMMENDATIONS

Bolting Dimensions

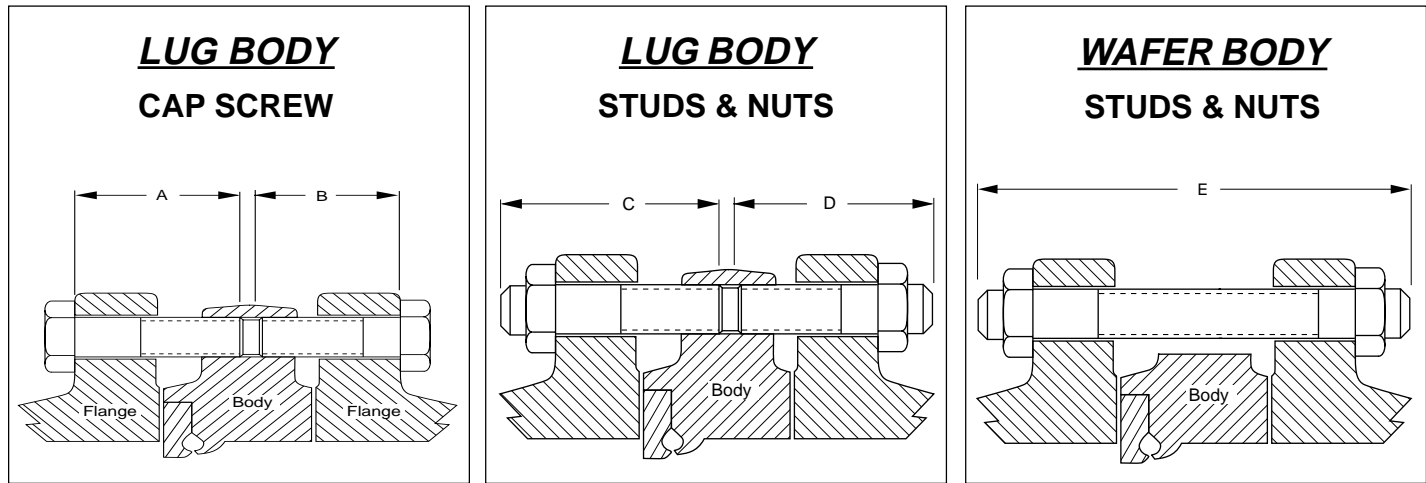

ANSI Class 150 2" – 24" MSS SP-44 Class 150 30"

| VALVE SIZE | VALVE SERIES | THREAD SIZE | LUG VALVES | | | | | | | | WAFFER VALVES | |
|------------|--------------|-------------|------------|--------|-----|--------|--------------|--------|-----|--------|---------------|--------|
| | | | CAP SCREW | | | | STUDS & NUTS | | | | STUDS & NUTS | |
| | | | QTY | LENGTH | QTY | LENGTH | QTY | LENGTH | QTY | LENGTH | QTY | LENGTH |
| | | | A | A | B | B | C | C | D | D | E | E |
| 2" | G | 5/8-11 | 4 | 1.50 | 4 | 1.50 | 4 | 2.25 | 4 | 2.25 | 4 | 5.00 |
| 2 1/2" | G | 5/8-11 | 4 | 1.88 | 4 | 1.81 | 4 | 2.63 | 4 | 2.63 | 4 | 5.50 |
| 3" | G | 5/8-11 | 4 | 2.13 | 4 | 1.69 | 4 | 3.00 | 4 | 2.50 | 4 | 5.75 |
| 4" | G | 5/8-11 | 8 | 2.00 | 8 | 1.75 | 8 | 3.00 | 8 | 2.50 | 8 | 5.88 |
| 5" | G | 3/4-10 | 8 | 1.88 | 8 | 1.93 | 8 | 3.00 | 8 | 3.00 | 8 | 6.13 |
| 6" | G | 3/4-10 | 8 | 2.38 | 8 | 1.88 | 8 | 3.50 | 8 | 3.00 | 8 | 6.25 |
| 8" | G | 3/4-10 | 8 | 2.63 | 8 | 2.13 | 8 | 3.63 | 8 | 3.06 | 8 | 6.75 |
| 10" | G | 7/8-9 | 12 | 3.00 | 12 | 2.38 | 12 | 4.13 | 12 | 3.50 | 12 | 7.50 |
| 12" | G | 7/8-9 | 12 | 3.38 | 12 | 2.25 | 12 | 4.50 | 12 | 3.50 | 12 | 8.25 |
| 14" | G | 1-8 | 12 | 3.63 | 12 | 2.62 | 12 | 5.00 | 12 | 4.00 | 12 | 9.00 |
| 16" | G | 1-8 | 16 | 4.13 | 16 | 2.75 | 16 | 5.50 | 16 | 4.00 | 16 | 9.50 |
| 18" | G | 1 1/8-8 | 16 | 4.25 | 16 | 3.25 | 16 | 5.75 | 16 | 4.75 | 16 | 10.50 |
| 20" | G | 1 1/8-8 | 16 | 5.13 | 16 | 3.19 | 16 | 6.50 | 16 | 4.50 | 16 | 11.25 |
| | G | 1 1/8-8 | 4* | 4.06 | 4 | 4.06 | 4 | 5.50 | 4 | 4.50 | 8* | 5.25 |
| 24" | G | 1 1/4-8 | 20 | 5.63 | 20 | 4.13 | 20 | 7.25 | 20 | 5.75 | 20 | 13.00 |
| 30" | H | 1 1/4-8 | 24 | 6.47 | 24 | 6.13 | 24 | 8.13 | 24 | 7.75 | 24 | 16.00 |
| | H | 1 1/4-8 | 4* | 4.93 | 4 | 4.50 | 4 | 6.50 | 4 | 6.25 | 8* | 6.00 |

Length of machine bolts based on:

1. Gasket thickness of 0.06 inches.
2. Minimum flange thickness of weld neck flanges per ANSI B16.5.

* The two bolt holes on either side of the shaft at the top and bottom of both sides of the body, are tapped blind holes, which require special length.

Every effort is made to provide accurate information, but no liability for claims arising from erroneous data will be accepted by Flowseal.

INSTALLATION RECOMMENDATIONS

Bolting Dimensions

| ANSI Class 300 2" – 24" | | | | | | | | | | | | |
|-------------------------|-------------|---------|------------|--------|-----|--------|--------------|--------|-----|--------|--------------|--------|
| MSS SP-44 Class 300 30" | | | | | | | | | | | | |
| VALVE SIZE | | | LUG VALVES | | | | | | | | WAFER VALVES | |
| | | | CAP SCREW | | | | STUDS & NUTS | | | | STUDS & NUTS | |
| | | | QTY | LENGTH | QTY | LENGTH | QTY | LENGTH | QTY | LENGTH | QTY | LENGTH |
| VALVE SERIES | THREAD SIZE | A | A | B | B | C | C | D | D | E | E | |
| 2" | G | 5/8-11 | 8 | 1.63 | 8 | 1.63 | 8 | 2.50 | 8 | 2.50 | 8 | 5.25 |
| 2 1/2" | G | 3/4-10 | 8 | 1.88 | 8 | 1.88 | 8 | 2.88 | 8 | 2.88 | 8 | 5.88 |
| 3" | G | 3/4-10 | 8 | 2.13 | 8 | 2.00 | 8 | 3.25 | 8 | 3.00 | 8 | 6.25 |
| 4" | G | 3/4-10 | 8 | 2.50 | 8 | 2.13 | 8 | 3.50 | 8 | 3.13 | 8 | 6.63 |
| 5" | G | 3/4-10 | 8 | 2.25 | 8 | 2.25 | 8 | 3.38 | 8 | 3.38 | 8 | 7.00 |
| 6" | G | 3/4-10 | 12 | 2.75 | 12 | 2.25 | 12 | 3.75 | 12 | 3.50 | 12 | 7.25 |
| 8" | G | 7/8-9 | 12 | 3.38 | 12 | 2.75 | 12 | 4.50 | 12 | 4.00 | 12 | 8.50 |
| 10" | G | 1-8 | 16 | 3.75 | 16 | 3.25 | 16 | 5.00 | 16 | 4.50 | 14 | 9.63 |
| | G | 1-8 | – | – | – | – | – | – | – | – | 4 | 5.00 |
| 12" | G | 1 1/8-8 | 16 | 4.00 | 16 | 3.50 | 16 | 5.50 | 16 | 5.00 | 12 | 10.63 |
| | G | 1 1/8-8 | – | – | – | – | – | – | – | – | 8 | 5.25 |
| 14" | H | 1 1/8-8 | 16 | 4.63 | 16 | 4.25 | 16 | 6.00 | 16 | 5.75 | 16 | 11.88 |
| | H | 1 1/8-8 | 4* | 3.75 | 4* | 3.44 | 4* | 5.25 | 4* | 5.00 | 8* | 5.25 |
| 16" | H | 1 1/4-8 | 16 | 4.75 | 16 | 4.93 | 16 | 6.50 | 16 | 6.50 | 16 | 13.00 |
| | H | 1 1/4-8 | 4* | 3.75 | 4* | 3.88 | 4* | 5.50 | 4* | 5.50 | 8* | 5.50 |
| 18" | H | 1 1/4-8 | 20 | 5.31 | 20 | 5.31 | 20 | 7.00 | 20 | 7.00 | 20 | 13.88 |
| | H | 1 1/4-8 | 4* | 4.00 | 4* | 3.88 | 4* | 5.75 | 4* | 5.50 | 8* | 5.50 |
| 20" | H | 1 1/4-8 | 20 | 5.75 | 20 | 5.50 | 20 | 7.50 | 20 | 7.13 | 20 | 14.63 |
| | H | 1 1/4-8 | 4* | 4.25 | 4* | 4.00 | 4* | 5.88 | 4* | 5.63 | 8* | 5.75 |
| 24" | H | 1 1/2-8 | 20 | 6.31 | 20 | 6.31 | 20 | 8.25 | 20 | 8.25 | 20 | 16.63 |
| | H | 1 1/2-8 | 4* | 4.50 | 4* | 4.50 | 4* | 6.50 | 4* | 6.50 | 8* | 6.50 |
| 30" | H | 1 3/4-8 | 24 | 8.00 | 24 | 8.00 | 24 | 10.25 | 24 | 10.25 | 24 | 20.50 |
| | H | 1 3/4-8 | 4* | 5.68 | 4* | 5.75 | 4* | 7.88 | 4* | 7.88 | 8* | 7.88 |

| ANSI Class 600 3" – 16" | | | | | | | | | | | | |
|-------------------------|-------------|---------|------------|--------|-----|--------|--------------|--------|-----|--------|--------------|--------|
| VALVE SIZE | | | LUG VALVES | | | | | | | | WAFER VALVES | |
| | | | CAP SCREW | | | | STUDS & NUTS | | | | STUDS & NUTS | |
| | | | QTY | LENGTH | QTY | LENGTH | QTY | LENGTH | QTY | LENGTH | QTY | LENGTH |
| VALVE SERIES | THREAD SIZE | A | A | B | B | C | C | D | D | E | E | |
| 3" | G | 3/4-10 | 8 | 2.50 | 8 | 2.50 | 8 | 3.50 | 8 | 3.50 | 8 | 7.13 |
| 4" | G | 7/8-9 | 8 | 3.00 | 8 | 3.00 | 8 | 4.13 | 8 | 4.00 | 8 | 8.25 |
| 6" | G | 1-8 | 12 | 3.50 | 12 | 3.50 | 12 | 4.63 | 12 | 4.63 | 12 | 10.00 |
| 8" | G | 1 1/8-8 | 12 | 4.25 | 12 | 4.25 | 12 | 5.63 | 12 | 5.63 | 12 | 11.75 |
| 10" | H | 1 1/4-8 | 12 | 5.25 | 12 | 4.75 | 12 | 6.75 | 12 | 6.63 | 12 | 13.75 |
| | H | 1 1/4-8 | 4* | 4.13 | 4* | 4.75 | 4* | 5.75 | 4* | 6.25 | 8* | 6.25 |
| 12" | H | 1 1/4-8 | 16 | 5.50 | 16 | 5.63 | 16 | 7.13 | 16 | 7.13 | 16 | 14.50 |
| | H | 1 1/4-8 | 4* | 4.25 | 4* | 4.63 | 4* | 5.75 | 4* | 6.25 | 8* | 6.25 |
| 14" | H | 1 3/8-8 | 16 | 5.75 | 16 | 5.75 | 16 | 7.50 | 16 | 7.50 | 16 | 15.63 |
| | H | 1 3/8-8 | 4* | 4.50 | 4* | 4.63 | 4* | 6.25 | 4* | 6.25 | 8* | 6.25 |
| 16" | H | 1 3/8-8 | 20 | 5.13 | 20 | 5.13 | 20 | 6.75 | 20 | 6.75 | N/A | N/A |

* The two bolt holes on either side of the shaft at the top and bottom of both sides of the body, are tapped blind holes, which require special length.

MAINTENANCE INSTRUCTIONS

SECTION 3

Safety Precautions

Before removing the valve from the line or loosening any bolts, it is important to verify the following conditions:

1. Be sure the line is depressurized and drained.
2. Be sure of the pipeline media. Proper care should be taken for protection against toxic and/or flammable fluids.
3. Never install the valve without an Operator (Manual or Automatic) already attached to the valve shaft.
4. Never remove the Operator from the valve while the valve is in the pipeline under pressure. Flowseal's eccentric valve design may allow line pressure to open the valve if the handle/actuator is not in place while the valve is under pressure.
5. Always be sure that the disc is in the full-closed position before removing or installing the valve.
6. Take care in handling the valve. Personal injury or property damage may result if the valve is damaged or mishandled during maintenance operations.

General Maintenance

Normal maintenance for a Flowseal HPBFV is limited to adjustment of the shaft packing by tightening down evenly on the gland flange using the gland flange studs and nuts. Overtightening of the gland should be avoided since this will shorten the life of the packing. During commissioning, it is common for dirt and foreign objects to be left in the pipeline during construction. This debris can damage the HPBV seat or disc edge which will prevent the valve from providing tight shut-off. In such cases seat replacement may be necessary.

Packing Replacement

1. Remove the handle or actuator and the mounting hardware from the valve.
2. Remove the gland flange nuts and lockwashers.
3. Remove the gland flange and gland.
4. Replace the old packing with new packing. Correct packing selection is important. On larger valves it may be necessary to compress each stem seal into the stuffing box before adding the next one.
5. Reinstall gland, gland flange, lockwashers and nuts.
6. Tighten the gland flange nuts evenly to torque specified in Table 1.
7. Operate the disc several times.
8. Reinstall the handle or actuator and mounting hardware.
9. Set the actuator stops.

Table 1

| Valve Size (in.) | Torque (in-lb) |
|------------------|----------------|
| 2 to 8 | 25 |
| 10 to 12 | 35 |
| 14 to 20 | 50 |
| 24 to 30 | 75 |
| 36 to 48 | 100 |

End Cap Seal Replacement

(where applicable)

1. Remove the end cap bolts and lockwashers.
2. Rotate the end cap to break the seal, then pull the cap out.
3. Remove the old seal.
4. Clean the body and end cap prior to installing the new seal.
5. Slide the new seal into place, then guide the end cap into the body.
6. Align the bolt holes and reinstall the lockwashers and bolts.
7. Tighten the bolts evenly to the torque specified in Table 2.

Table 2

| Valve Size (in.) | Torque (in-lb) |
|------------------|----------------|
| 2 to 8 | 50 |
| 10 to 12 | 80 |
| 14 to 30 | 100 |

Standard Soft Seat Replacement

1. Place the valve on a bench with the seat retainer facing up. Use blocks to elevate the valve above the work surface to provide enough clearance to prevent the disc from being damaged when the valve is opened.
2. (a) Cap Screw Retainer:
Remove the cap screws and lift the seat retainer out of the valve.
(b) Wedge Ring Retainer:
Unlock the retainer by removing the set screws. If difficulty is experienced in removing the retainer, open the disc approximately 20 degrees and then tap the retainer with a non-metallic hammer. Lift the retainer from the body.
3. Remove the old seat from the seat retainer and discard.
4. Thoroughly clean the seat cavity in the body and the seat retainer prior to installing a new seat.

MAINTENANCE INSTRUCTIONS

Standard Soft Seat Replacement (cont.)

5. Carefully clean and polish the disc sealing surface with a soft cloth. The disc sealing surface should be free of all grooves and scratches.
6. Place the seat retainer on a flat surface with the seat locating area facing up.
7. Place the new preformed seat assembly (Seat and O-ring) on the seat retainer with the marked (tape) side facing down.
8. Using the balls of each thumb, press down on the seat engaging the shoulder of the seat behind the lip in the seat retainer. Stretch the seat into place by sliding each thumb around the circumference of the seat maintaining downward pressure and forcing the seat shoulder over the seat retainer lip.
9. With the disc in the closed position place the seat retainer with seat into the counterbore of the body.
 - (a) Cap Screw Retainer:
Apply lubricant to the cap screw threads and tighten them down uniformly.
 - (b) Wedge Ring Retainer:
Place the wedge ring in the groove on the outside edge of the retainer taking care to position the wedge ring gap away from any set screw. Using opposing C-clamps, pull the retainer into a position flush with body face. (The C-clamps should not block access to the set screw holes.)
10. Open the disc and relax the retainer pressure slightly to permit the seat to expand fully inward against the seat retaining lip machined in the retainer and body seat cavities. A positive “snap” action will be observed.
 - (a) Cap Screw Retainer:
Leaving the valve disc open, retighten the cap screws to the torques specified in Table 3.
 - (b) Wedge Ring Retainer:
Leaving the valve disc open, retighten the C-clamps and install the set screws. Remove the C-clamps after all screws have been tightened.
11. Operate the disc several times and inspect the seat for damage before reinstalling the valve in the pipeline.
12. Inspect the position of the disc in the closed position to determine whether the actuator stops are adjusted properly. The face of the disc should be parallel to the seat retainer face when the valve is in the fully closed position.

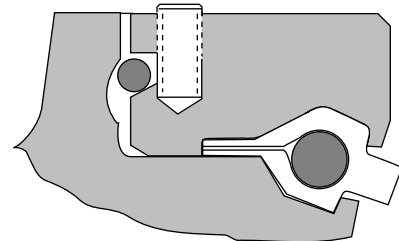
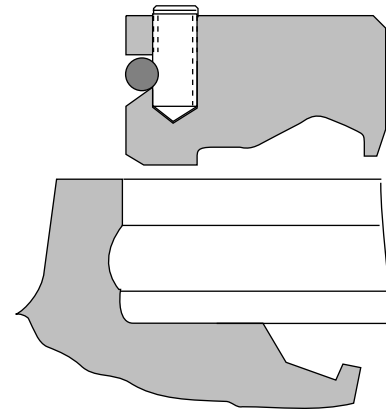
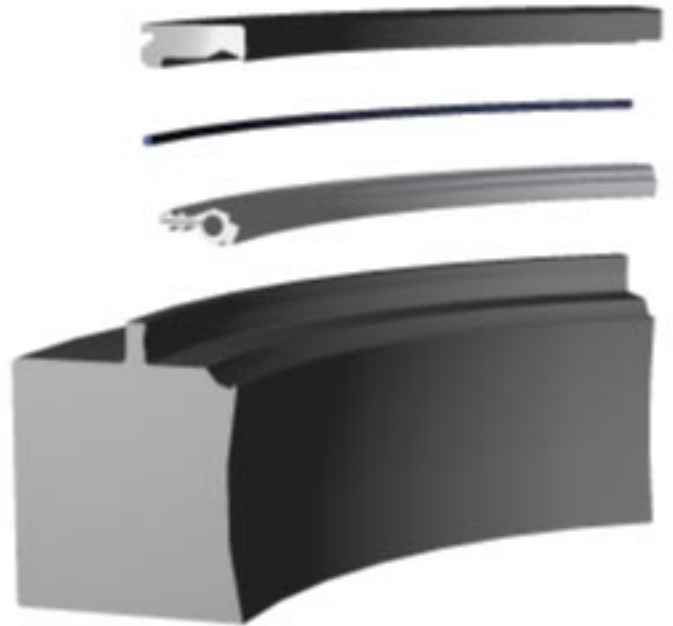

Table 3

| Valve Size (in.) | Torque (in-lb) |
|------------------|----------------|
| 2 to 12 | 50 |
| 14 to 20 | 75 |
| 24 to 48 | 100 |

MAINTENANCE INSTRUCTIONS

Fire-Flow and Metal Seat Replacement

1. Follow Steps 1 and 2 of Soft Seat Replacement instructions.
2. Remove old soft seat and graphite gaskets and discard. Clean and inspect the metal seat.
3. If metal seat is scored, bent or otherwise damaged it will require replacement.
4. Thoroughly clean the seat cavity in the body and the seat retainer prior to installing the new seat.
5. Carefully clean and polish the disc edge sealing surface with a soft cloth. The disc sealing surface should be free of all grooves and scratches.
6. A graphite gasket is required on both sides of the metal seat. Gaskets can be made from self-adhesive graphite tape as follows:
 - (a) Suggested graphite tape size:
 - 2" - 12" valves – 1/2" wide
 - 14" - 48" valves – 1" wide
 - (b) To install the tape, peel off 6" of backing paper at a time. Apply the tape to the metal seat covering the flat outer edge area on both sides. Overlap the two ends of the tape a minimum of 1/8 inch.
Note: It is important that both sides have gaskets.
 - (c) Smooth tape as much as possible by hand. Slight roughness is acceptable and will be pressed flat during final assembly. Avoid tearing tape. If a tear occurs, tape should be overlapped a minimum of 1/8 inch. Trim excess tape from outside diameter of the seat.
 - (d) If cap screw retainer design, bolt holes in metal seat should be opened by slitting an "X" in the hole. Do not attempt to cut round holes.
7. For Fire-Flow valves, place the preformed seat assembly in the body seat cavity with the marked (tape) side up. For metal seated valves, place the 316 SS back-up ring in the body seat cavity.
8. Place the metal seat with graphite gaskets on the TFE seat or 316 SS back-up ring already in the body. The metal seat should be installed with the rounded edge down against the TFE seat or the 316 SS back-up ring.
9. Follow steps 9 thru 12 of Soft Seat Replacement instructions.

Disc, Shaft and Bearing Replacement

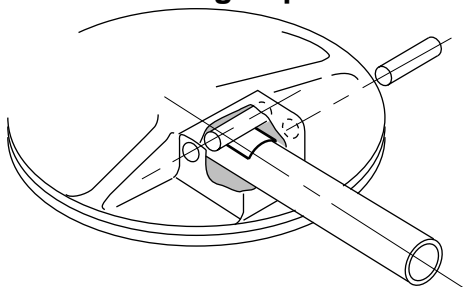

Flowseal uses a wedge pin method of disc/shaft pinning. This method permits the replacement of either a disc or a shaft since they are not required to be matched sets.

1. Remove any actuator and mounting bracket from top of valve.
2. Remove all top and bottom packing and/or end seals as required.
3. To prepare for removal of existing wedge pins, grind away any disc material that has been peened over pin heads.
4. (a) For Through Shaft Design:
Using a punch approximately the same size as the wedge pins, drive each pin out of the disc hub from the non-peened side of the disc to the peened side of the disc.
- (b) For Split Shaft Design:
Pull the wedge pins out of the disc hub using the threaded holes on top of each pin and a jack screw.
5. Support the valve body and disc on a flat surface in the horizontal position. Slowly remove shaft(s).
6. Remove the disc from the body.
7. To remove bearings, cut or grind a slot lengthwise in each bearing in order to be able to collapse bearing prior to removal. Be careful not to damage bearing seating bore within the body.
8. Clean all components thoroughly.
9. Inspect all parts for damage prior to reassembly. Damaged parts should be repaired or replaced with new parts.
10. Carefully clean and polish the disc sealing surface with a soft cloth. The disc sealing surface should be free of all grooves and scratches.
Install the new bearings by gently tapping them into the body with a soft rod and hammer. The bearings should be
11. installed into the shaft bore firmly against the counterbore or bottom of shaft hole.
12. (a) Valves 2" thru 12":
With the valve body on edge on the bench, shaft horizontal, and the body overtravel stop nearest to the bench, position the disc in the open position with the flat face upward. Present the disc to the valve body from the side opposite the seat retainer cavity.
- (b) Valves 14" and larger:
Support the disc on a bench, flat side down and elevated above the bench top to a height of approximately 4 inches. Lower the valve body over the disc, seatretainer side facing upward, until the bearing bore and disc hole are aligned. Install the shaft into the body and disc.
13. The shaft keyway when viewed from the top of the valve should be to the right, which is also the direction from which the pins are installed.

MAINTENANCE INSTRUCTIONS

14. Line up the shaft flat to permit the insertion of the wedge pins. Install the first wedge pin in the disc hole closest to the top of the valve. Finger tight installation is appropriate.
15. Move the shaft fully into the valve and against this first installed pin. Insert the second pin. Tap both wedge pins in equal amounts until all play between shaft and disc is removed. Care should be taken not to attempt to over seat the wedge pins. If the pin is flush or protruding after tapping in, tack weld on the opposite side for security. Otherwise, peening of the installing side is recommended.
16. Install a new end seal if applicable with the end cap as described in Steps 4 through 7 of the End Cap Seal Replacement procedure.
17. Install new packing box components as described in Steps 4 through 10 of the Packing Replacement procedure.
18. Install new seat as described in the Seat Replacement procedure.
19. Cycle the valve several times to ensure the disc is pinned tightly to the shaft and there is no shaft binding or seat damage before reinstalling the valve in the pipeline.
20. Reinstall the actuator mounting hardware and actuator.
21. Set the actuator stops.

Ratchet Handle Mounting Procedure

1. Position the disc in the closed position.
2. Install the ratchet plate using socket head cap screws and lockwashers, but do not tighten the fasteners.
3. Install the drive key in the shaft. Tap the key into place to ensure it is fully seated in the keyway .
4. Install the handle so that it is parallel with the disc face. The locking lever must be fully retracted before it will pass through the ratchet plate. Tighten the set screw in the handle against the key.
5. With the handle installed flush with the ratchet plate, engage the locking lever with the ratchet plate. Using the handle, adjust the position of the ratchet plate until the disc face is parallel with the valve face, then tighten the fasteners securely.

Changing the Quadrant:

If it is necessary to relocate the handle 180° from its standard position, complete the following steps:

1. Remove the handle by disengaging the locking lever and lifting up. The locking lever will slide thru the ratchet plate only in the disengaged position.
2. Remove the ratchet plate fasteners and rotate the plate 180°. Reinstall the fasteners but do not tighten them.
3. Reinstall the handle 180° from the standard position so that it is parallel with the disc (Note: The locking lever must be disengaged). Tighten the handle set screw against the key.
4. Adjust the ratchet plate as described above.

Manual Gear Mounting Procedure

1. Position the disc in the closed position.
2. Install the mounting bracket on the valve body. Fasten it tightly in place with the appropriate machine bolts and lockwashers.
3. Install the drive key in the shaft. Tap the key into place to ensure it is fully seated.
4. Rotate the gear shaft to the full clockwise position. Align the keyway in the gearbox bore with the key in the shaft and slide the gearbox onto the shaft.
5. Fasten the gearbox to the mounting bracket with the appropriate machine bolts and lockwashers. It may be necessary to rotate the gear shaft slightly to align the mounting holes in the gear with the plate.
6. Adjust the stops in the gearbox to position the face of the disc parallel with the face of the valve in the closed position and perpendicular to the face of the valve in the open position.

Changing the Quadrant:

If it is necessary to relocate the manual gear handwheel 180° from its standard position, complete the following steps:

1. Close the valve.
2. Remove the bolts and lockwashers holding the gearbox to the mounting bracket. Lift the gearbox off the shaft.
3. Rotate the gearbox 180° around the shaft.
4. Align the key with the gearbox keyseat and slide the gearbox onto the shaft.
5. Reinstall the bolts and lockwashers to fasten the gearbox to the mounting bracket.
6. Adjust the gearbox stops as described previously.

Remote Actuator (Male Drive) Mounting Procedure

1. Position the disc in the closed position.
2. Install the actuator mounting bracket on the valve body with the actuator mounting holes facing up-ward. Fasten the bracket securely in place with the appropriate machine bolts and lockwashers.
3. Install the drive key in the keyway of the shaft. Tap the key in place to insure it is fully seated.
4. Install the drive coupling on the shaft by lining up the proper keyway in the coupling with the key in the shaft.
5. Rotate the actuator shaft to the full clockwise position. Align the drive coupling with the actuator shaft and install the actuator on the mounting bracket.
6. Fasten the actuator to the mounting bracket with the appropriate machine bolts and lockwashers. It may be necessary to slightly rotate the actuator shaft to align the mounting holes in the actuator with the mounting bracket.

MAINTENANCE INSTRUCTIONS

Remote Actuator (Male Drive) Mounting Procedure (cont.)

7. Adjust the stops in the actuator to position the face of the disc parallel with the face of the valve body in the closed position and perpendicular to the face of the valve body in the open position.

Caution: *The overtravel stop in the valve body is not to be used as an actuator stop.*

Changing the Quadrant:

If it is necessary to rotate the actuator 90° from standard position, complete the following steps:

1. Close the valve.
2. Remove the bolts and lockwashers holding the actuator to the mounting bracket. Lift the actuator off the mounting bracket.
3. Remove the drive coupling from the valve shaft and rotate it 90° to the adjacent keyway.
4. Reinstall the drive coupling on the valve shaft.
5. Align the drive coupling with the actuator shaft and install the actuator on the mounting bracket.
6. Reinstall the bolts and lockwashers to fasten the actuator to the mounting bracket.
7. Adjust the actuator stops as described above.

If it is necessary to rotate the actuator 180° from standard position, complete the following steps.

1. Close the valve.
2. Remove the bolts and lockwashers holding the actuator to the mounting bracket.
3. Lift the actuator off the mounting bracket. Rotate the actuator 180°.
4. Align the drive coupling with the actuator shaft and install the actuator on the mounting bracket.
5. Reinstall the bolts and lockwashers to fasten the actuator to the mounting bracket.
6. Adjust the actuator stops as described previously.

Remote Actuator (Female Drive) Mounting Procedure

1. Position the disc in the closed position.
2. Install the actuator mounting bracket on the valve body with the actuator mounting holes facing up. Fasten the bracket securely in place with the appropriate machine bolts and lockwashers.
3. Install the drive key in the shaft. Tap the key in place to insure it is fully seated.
4. Install the drive coupling on the shaft by lining up the proper coupling keyway with the key in the shaft.
5. Install the drive key in the drive coupling. Tap the key in place to insure it is properly seated.

6. Rotate the actuator to the full clockwise position. Align the keyway in the actuator bore with the key in the drive coupling and slide the actuator on the drive coupling.
7. Fasten the actuator to the mounting bracket with the appropriate machine bolts and lockwashers. It may be necessary to rotate the actuator slightly to align the actuator with the mounting bracket.
8. Adjust the stops in the actuator to position the face of the disc parallel with the face of the valve body in the closed position and perpendicular to the face of the valve body in the open position.

Caution: *The overtravel stop in the valve body is not to be used as an actuator stop.*

Changing the Quadrant:

If it is necessary to rotate the actuator 90° from standard position complete the following steps:

1. Close the valve.
2. Remove the bolts and lockwashers holding the actuator to the mounting bracket.
3. Lift the actuator off the mounting bracket.
4. Remove the key from the drive coupling and reinstall in the adjacent keyway 90° away. Tap the key in place to ensure it is fully seated.
5. Align the keyway in the actuator bore with the key in the drive coupling and slide the actuator onto the drive coupling.
6. Reinstall the bolts and lockwashers to fasten the actuator to the mounting bracket.
7. Adjust the actuator stops as described previously.

If it is necessary to rotate the actuator 180° from its standard position, complete the following steps:

1. Close the valve.
2. Remove the bolts and lockwashers holding the actuator to the mounting bracket.
3. Lift the actuator off the mounting bracket.
4. Remove the drive coupling from the valve shaft and rotate it 90°.
5. Reinstall the drive coupling on the valve shaft.
6. Remove the key from the drive coupling and reinstall the key in the adjacent keyway 90° away. Tap the key in place to ensure it is fully seated.
7. Align the keyway in the actuator bore with the key in the drive coupling and slide the actuator onto the drive coupling.
8. Reinstall the bolts and lockwashers to fasten the actuator to the mounting bracket.
9. Adjust the actuator stops as described previously.

MAINTENANCE INSTRUCTIONS

Parts List

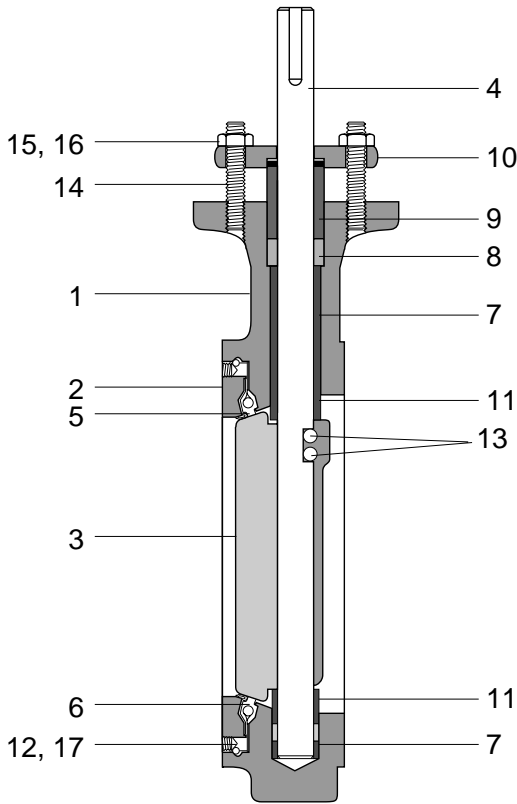

Through Shaft Design

| Item | Description |
|------|----------------------------|
| 1 | Body |
| 2 | Seat Retainer |
| 3 | Disc |
| 4 | Shaft |
| 5 | Seat |
| 6 | Seat O-ring |
| 7 | Bearing |
| 8 | Packing |
| 9 | Gland |
| 10 | Gland Follower |
| 11 | Disc Thrust Spacer (2"-5") |
| 12 | Set Screws |
| 13 | Wedge Pins |
| 14 | Gland Flange Stud |
| 15 | Gland Flange Nut |
| 16 | Lockwasher |
| 17 | Wedge Ring |

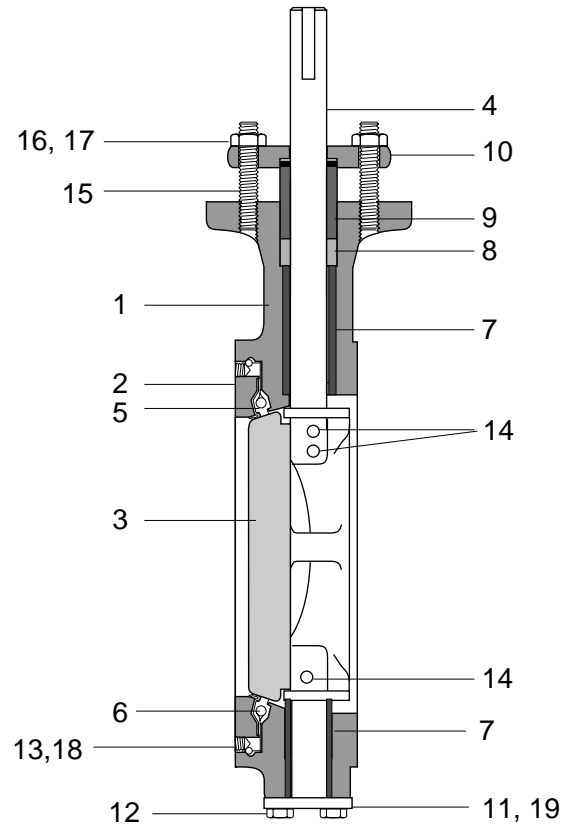

Split Shaft Design

| Item | Description |
|------|-------------------|
| 1 | Body |
| 2 | Seat Retainer |
| 3 | Disc |
| 4 | Shaft |
| 5 | Seat |
| 6 | Seat O-ring |
| 7 | Bearing |
| 8 | Packing |
| 9 | Gland |
| 10 | Gland Follower |
| 11 | End Cap |
| 12 | End Cap Bolts |
| 13 | Set Screws |
| 14 | Wedge Pins |
| 15 | Gland Flange Stud |
| 16 | Gland Flange Nut |
| 17 | Lockwasher |
| 18 | Wedge Ring |
| 19 | End Cap Seal |

