

# NELSON HEAT TRACING SYSTEMS

## HASK-E HAZARDOUS AREA SEAL KIT

### FOR DIV. 1 CABLE TERMINATION & EXPLOSION PROOF SEAL

### INSTALLATION INSTRUCTIONS

#### DESCRIPTION

The HASK-E Hazardous Area Seal Kit provides the cable termination and explosion proof seal parts needed to make the end of circuit electrical connections associated with Nelson Heat Tracing Systems' self-regulating heater cables.

#### KIT CONTENTS

- |                    |                     |
|--------------------|---------------------|
| 1 Junction Box     | 1 Stand-off         |
| 1 Tube of Silicone | 1 Power Termination |
| 1 Sealing Compound | 1 Terminal Block    |
| 1 Sealing Grommet  | 1 X Fiber           |
| 2 Conduit Plugs    | 1 Seal Fitting      |
| 2 Pipe Clamps      | 1 Male Adapter      |

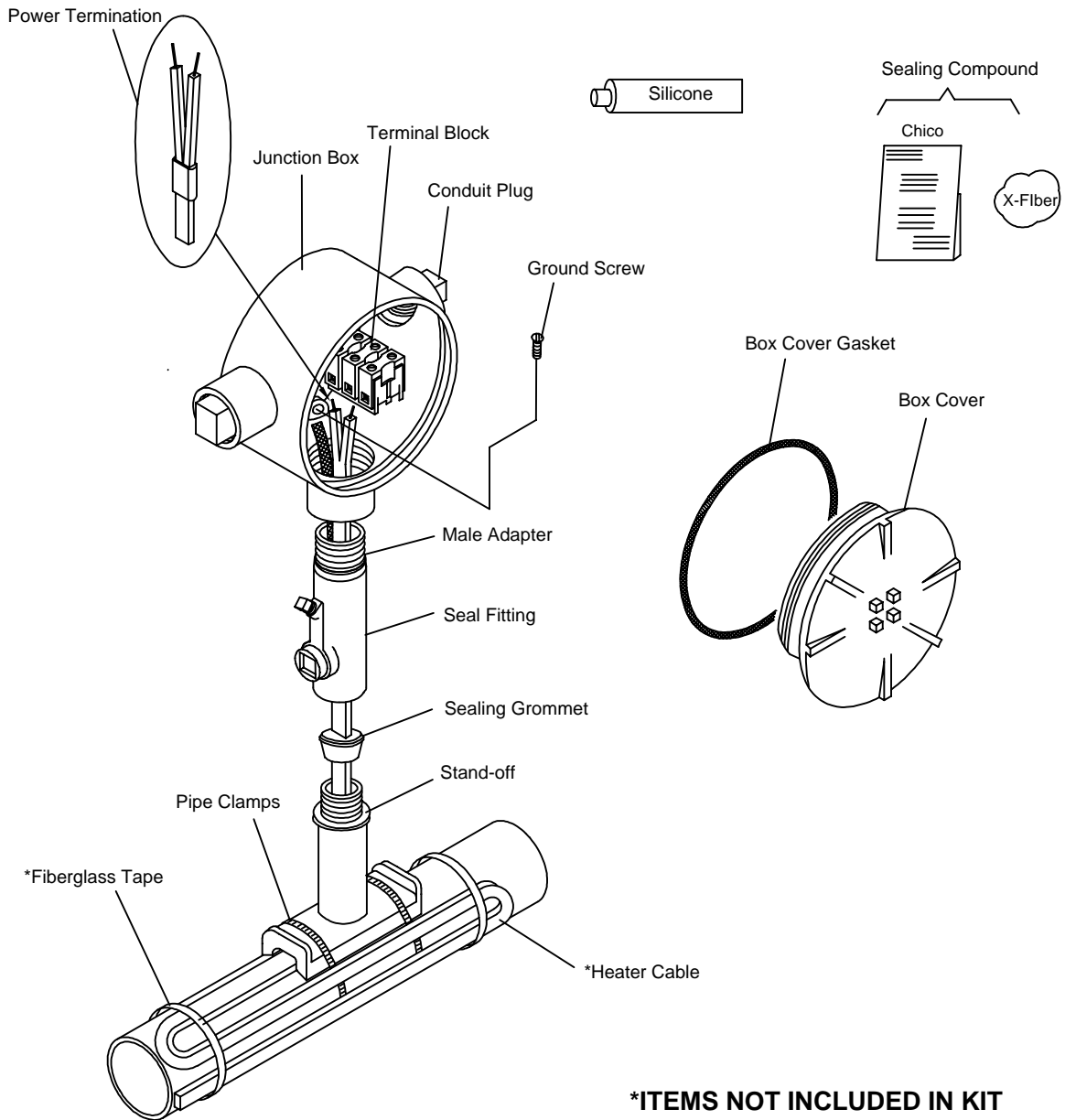

# NELSON HEAT TRACING SYSTEMS

## HASK-E HAZARDOUS AREA SEAL KIT FOR DIV. 1 CABLE TERMINATION & EXPLOSION PROOF SEAL

## INSTALLATION INSTRUCTIONS

### STAND-OFF POSITIONING

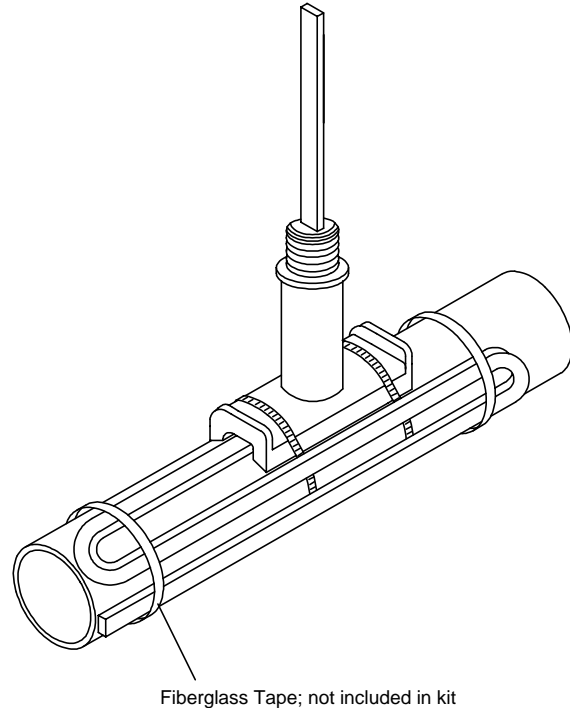
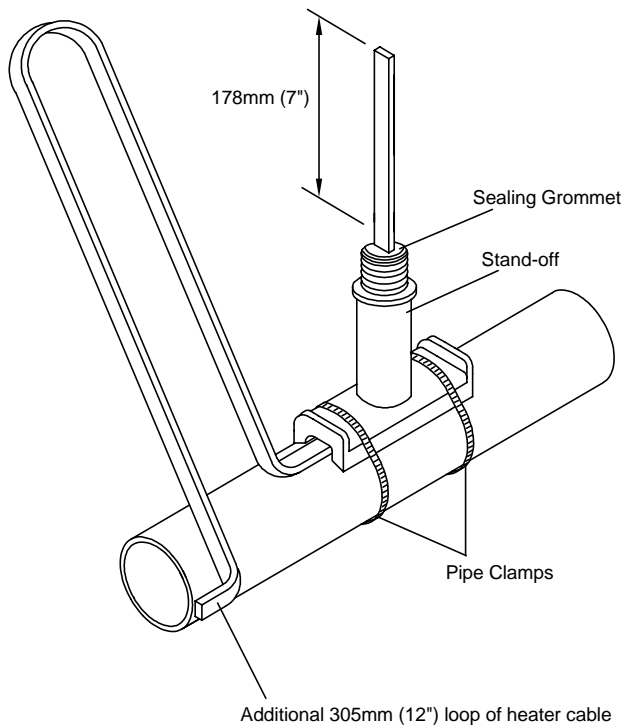

#### **⚠ WARNING:**

**Do not install pipe clamps over the heater cable.**

- 1 Push heater cable through the bottom opening of the stand-off. Allow 178mm (7") of heater cable for termination. Leave a 305mm (12") loop of additional cable to be installed after the stand-off is secured.
- 2 Mount stand-off to pipe using the pipe clamps included in kit.
- 3 Slide the sealing grommet over heater cable and position at stand-off.

- 4 Secure the additional 305mm (12") of heater to the pipe using fiberglass tape (not included in kit).
- 5 Prepare heater cable for termination. Proceed to "Overjacket Stripping Procedures" on sheet 3.

# NELSON HEAT TRACING SYSTEMS

## HASK-E HAZARDOUS AREA SEAL KIT FOR DIV. 1 CABLE TERMINATION & EXPLOSION PROOF SEAL

## INSTALLATION INSTRUCTIONS

### OVERJACKET STRIPPING PROCEDURES

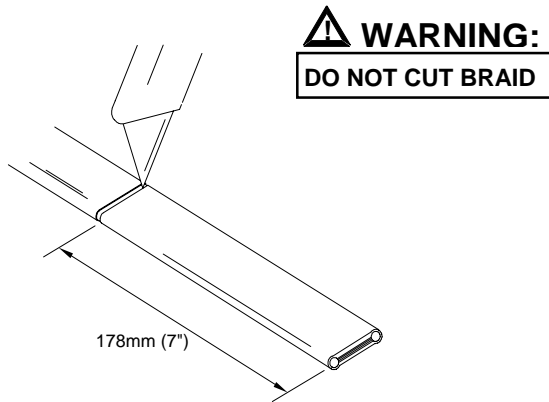

- 1 Lightly cut around heater overjacket 178mm (7") from the end. Bend cable to break overjacket.
- 2 Lightly cut overjacket up the center between first cut mark and the cable end. Bend cable to break overjacket.

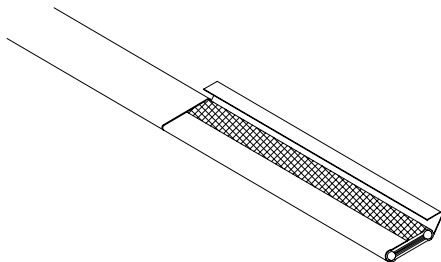

- 3 Remove overjacket from heater cable.

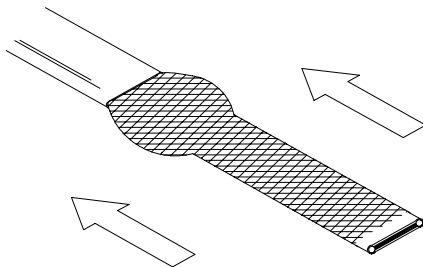

- 4 Move braid back toward the overjacket, creating a bulge.

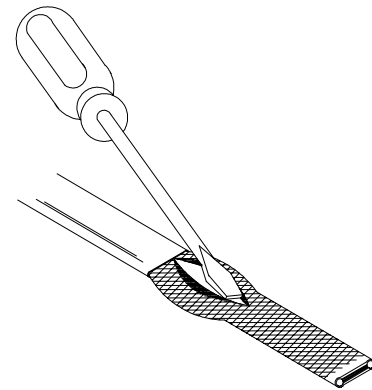

- 5 At the bulge, separate the braid to make an opening.

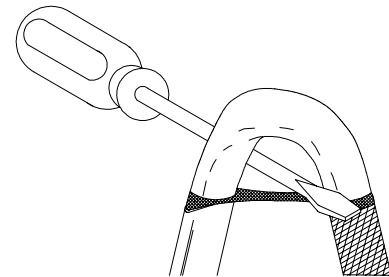

- 6 While bending the heater cable, work it through the braid opening.

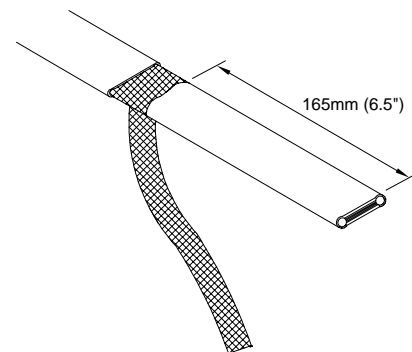

- 7 Pull the braid tight.
- 8 Proceed to "Outer Jacket Stripping Procedures" on sheet 4.

# NELSON HEAT TRACING SYSTEMS

## HASK-E HAZARDOUS AREA SEAL KIT FOR DIV. 1 CABLE TERMINATION & EXPLOSION PROOF SEAL

## INSTALLATION INSTRUCTIONS

### OUTER JACKET STRIPPING PROCEDURES

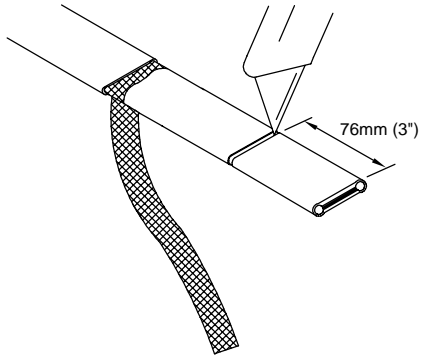

- 1 Lightly cut around heater outer jacket 76mm (3") from the end. Bend cable to break outer jacket.
- 2 Lightly cut the outer jacket up the center between the first cut mark & the cable end. Bend cable to break outer jacket.

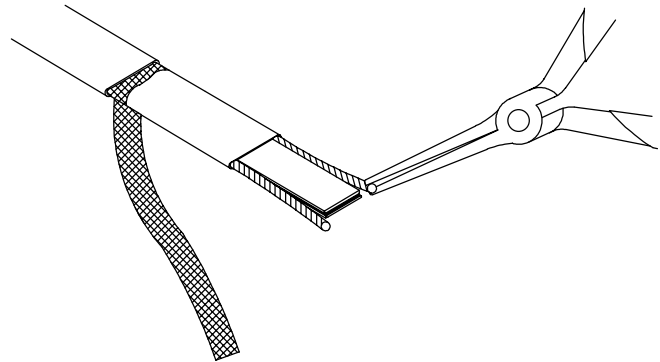

- 5 Starting at the end, pull each bus wire away from the core material.
- 6 Remove exposed core material.

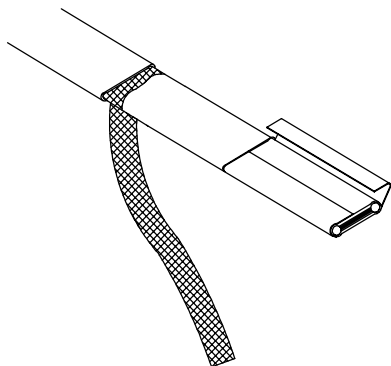

- 3 Remove the jacket from the heater cable.

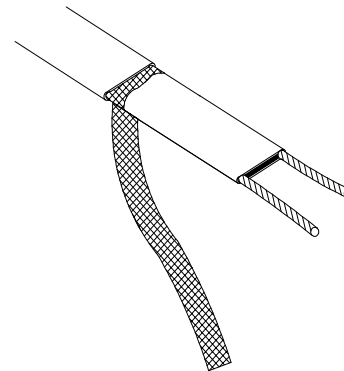

- 7 Cut 6mm (0.25") off the end of each bus wire.
- 8 Proceed to "Power Termination" on sheet 5.

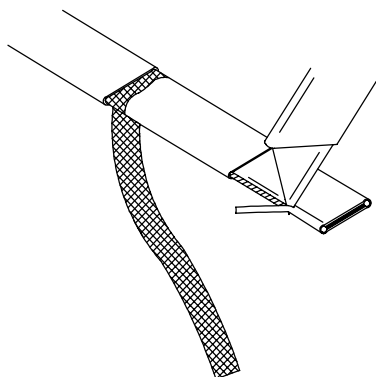

- 4 Shave the core material from the outside of each bus wire.

**⚠ WARNING:**  
**DO NOT CUT BUS WIRES**

# NELSON HEAT TRACING SYSTEMS

## HASK-E HAZARDOUS AREA SEAL KIT FOR DIV. 1 CABLE TERMINATION & EXPLOSION PROOF SEAL

## INSTALLATION INSTRUCTIONS

### POWER TERMINATION

#### **WARNING:**

- Bus wires must not touch or cross while inserting into power termination.
- Only power terminations specifically approved for the vendors style and type of heater cable must be used.

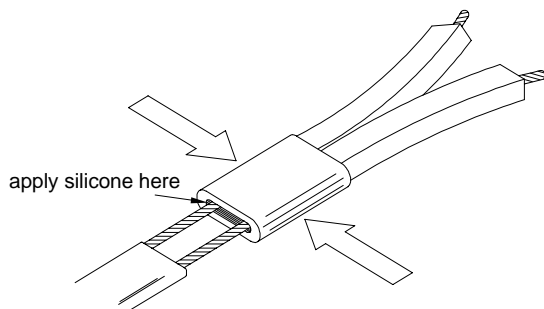

- 1 Insert bus wires into power termination.
- 2 Squeeze power termination opening and fill with silicone.

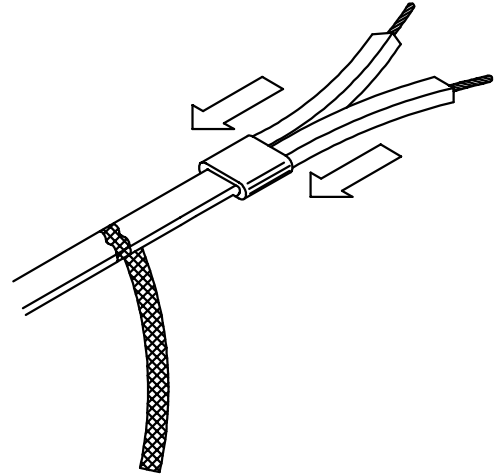

- 3 Push power termination to overlap jacket.
- 4 Proceed to "Seal Fitting Installation" on sheet 6.

# NELSON HEAT TRACING SYSTEMS

## HASK-E HAZARDOUS AREA SEAL KIT FOR DIV. 1 CABLE TERMINATION & EXPLOSION PROOF SEAL

## INSTALLATION INSTRUCTIONS

### SEAL FITTING INSTALLATION

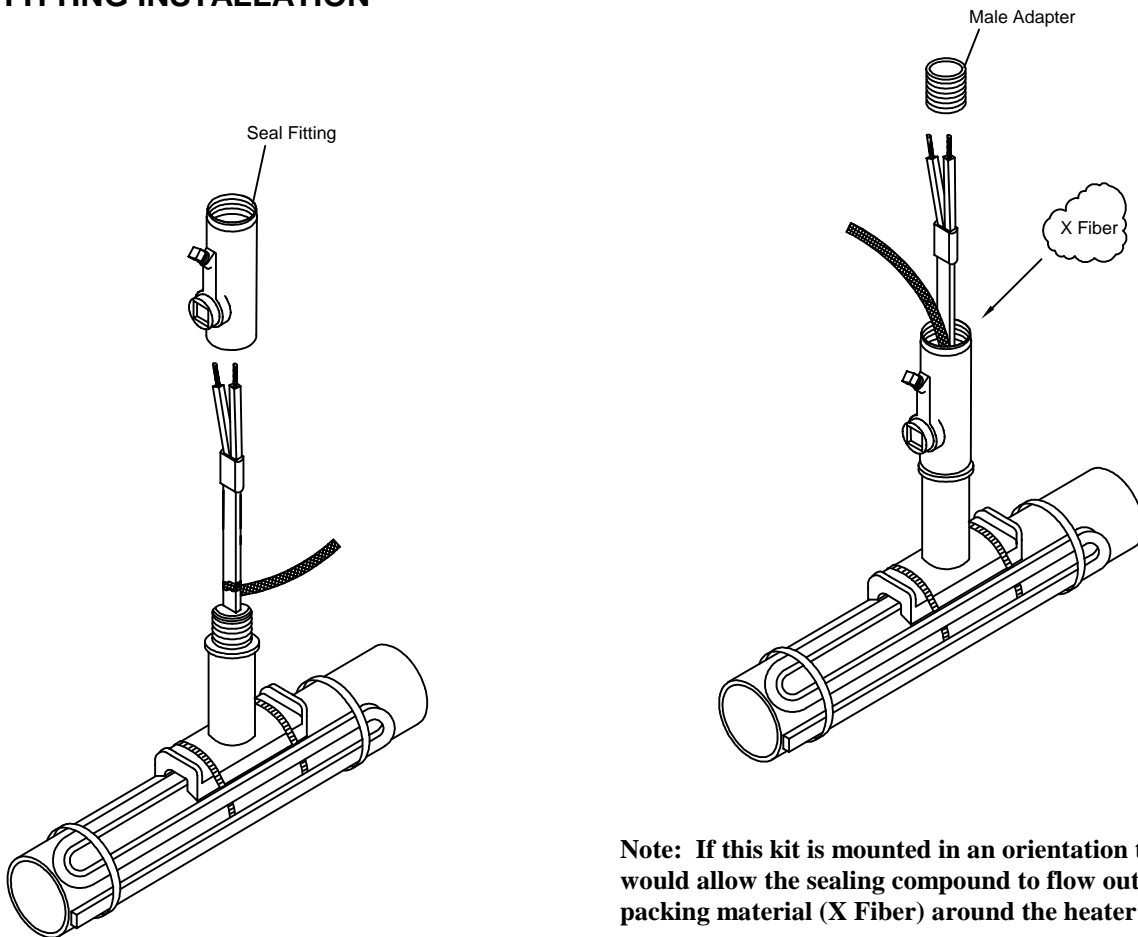

- 1 Slide seal fitting over the heater cable and braid, screw onto the stand-off by hand until snug fit.

**Note:** The heater cable must be positioned in the seal fitting so the braid transition point is visible through the seal fitting opening. See Detail "A" on sheet 8.

**Note:** If this kit is mounted in an orientation that would allow the sealing compound to flow out, place packing material (X Fiber) around the heater cable.

- 2 Slide male adapter over the heater cable and braid, screw into seal fitting by hand until snug fit.
- 3 Proceed to "Sealing Compound Procedure" on sheet 7.

# NELSON HEAT TRACING SYSTEMS

## HASK-E HAZARDOUS AREA SEAL KIT FOR DIV. 1 CABLE TERMINATION & EXPLOSION PROOF SEAL

## INSTALLATION INSTRUCTIONS

### SEALING COMPOUND PROCEDURE

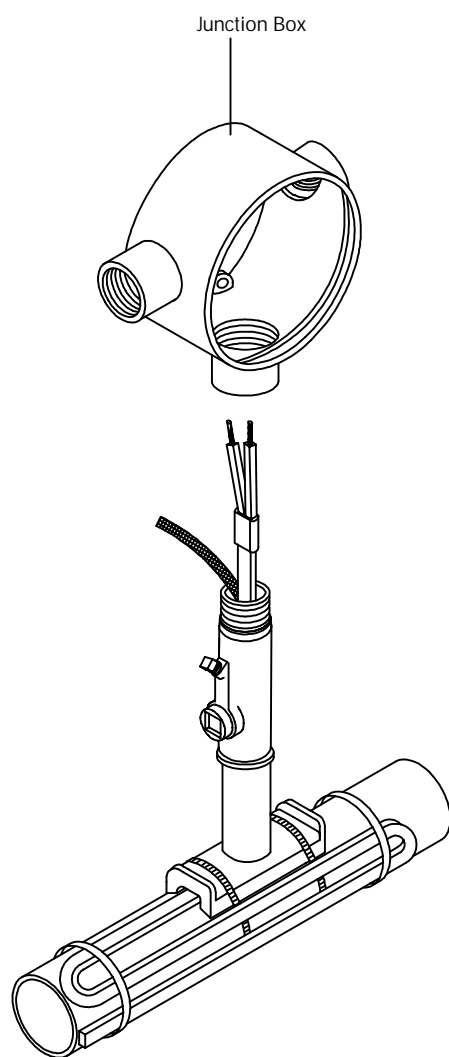

- 1 Place junction box over the heater cable and braid, screw onto male adapter until secure.

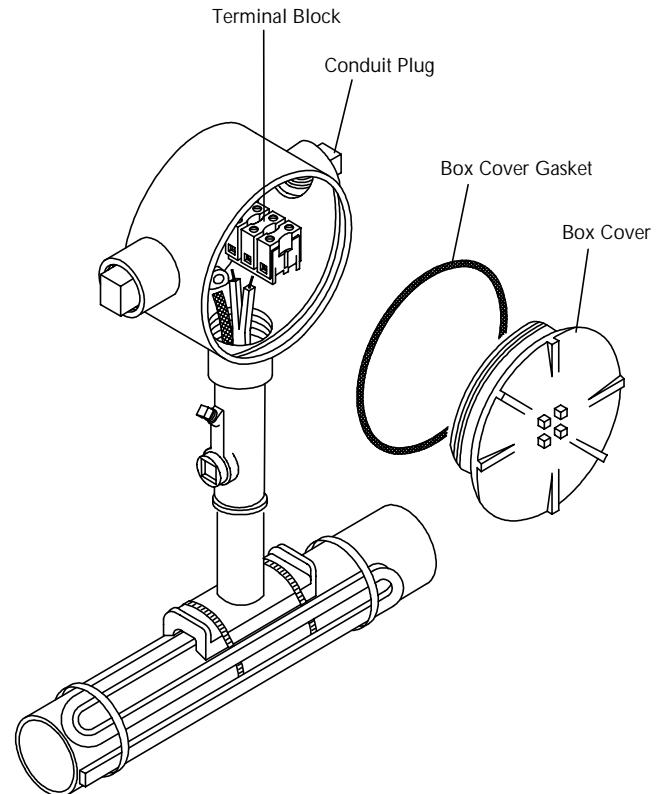

- 2 Connect bus wires to terminal block, one per terminal. Connect braid to green ground screw.
- 3 Place the box cover gasket and box cover onto junction box. Plug the unused conduit openings with the conduit plugs.
- 4 Mix sealing compound according to the instructions on the pouch (knead to mix liquid and powder in pouch). Snip off a corner of the pouch and fill the seal fitting.

### **⚠ WARNING:**

Sealing compound must completely cover the braid transition point. See Detail "A" on sheet 8 for reference.

# NELSON HEAT TRACING SYSTEMS

## HASK-E HAZARDOUS AREA SEAL KIT FOR DIV. 1 CABLE TERMINATION & EXPLOSION PROOF SEAL

## INSTALLATION INSTRUCTIONS

### TEMPLATE

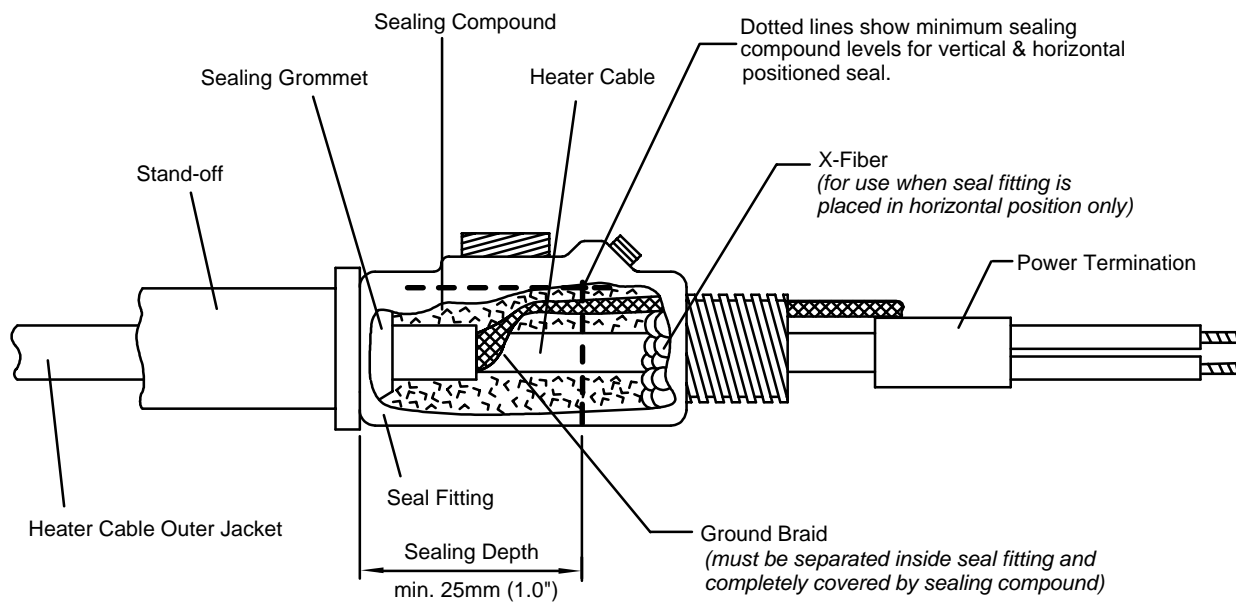
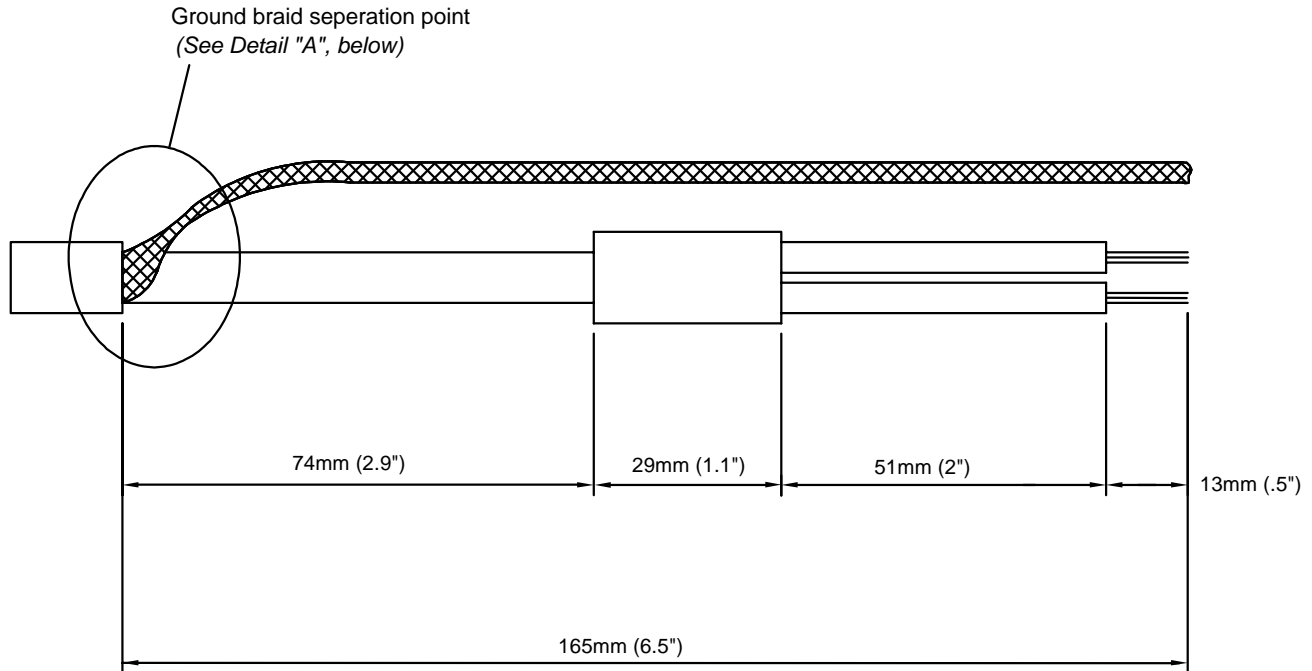

**DETAIL "A"**