

NELSON HEAT TRACING SYSTEMS

PLT-L SERIES END OF CIRCUIT LIGHT KIT

INSTALLATION INSTRUCTIONS

DESCRIPTION

The PLT-L Series End of Circuit Light Kit is for use with all versions of LT, CLT, HLT and NC heater cables. Compatible for use with any vendors heater cables smaller than 11mm (.44") diameter.

KIT CONTENTS

1 Junction Box	1 Power Termination
1 Conduit Locknut	1 Box Adapter
1 Sealing Grommet	1 Gasket
1 Stand-off	1 Tube of Silicone
1 Caution Label	2 Pipe Clamps
1 Light Assembly	3 Gaskets (soft)

Voltage	Kit Cat. #
120V	PLT-L120
208V	PLT-L208
240V	PLT-L240
277V	PLT-L277

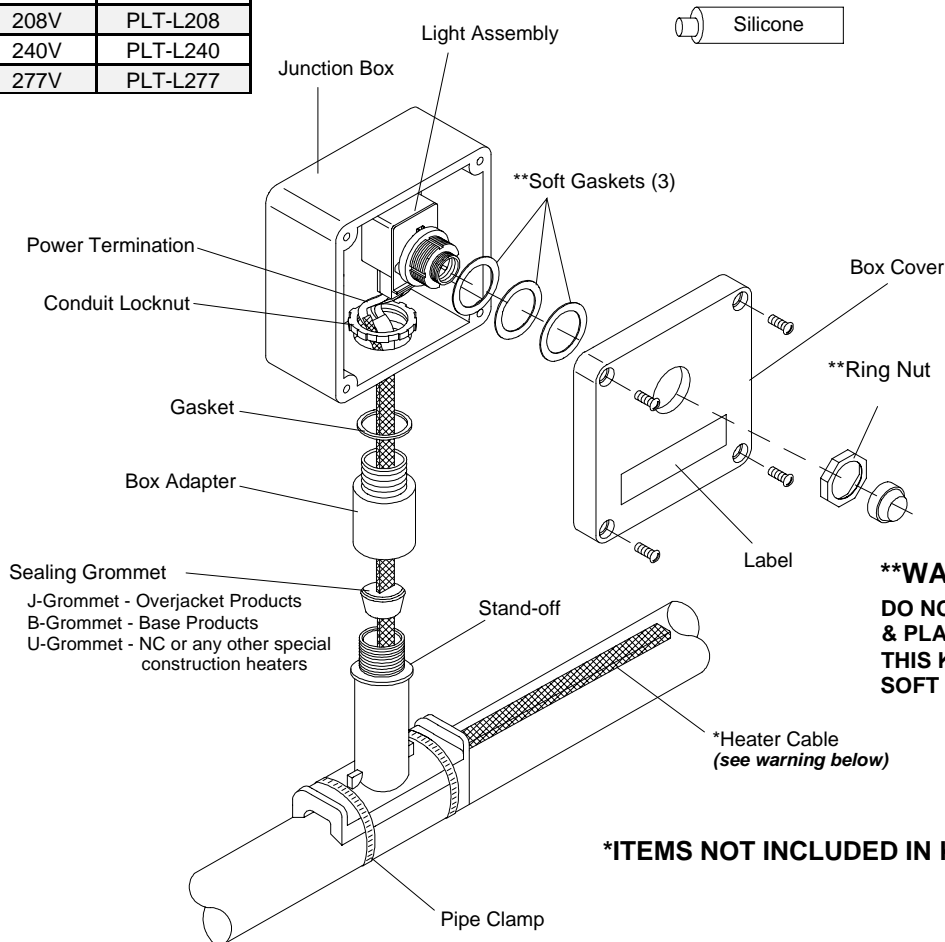

Note: This detail shows Braided "CB" Products only. For Overjacket "J" or "JT" Products see diagram on sheet 8.

⚠ WARNING:

Article 427-22 of the National Electrical Code requires that all heaters shall have metal coverings and be provided with branch circuit ground-fault protection.

STAND-OFF POSITIONING

Section View A A

(recommend installing at the
4 or 8 o'clock positions.)

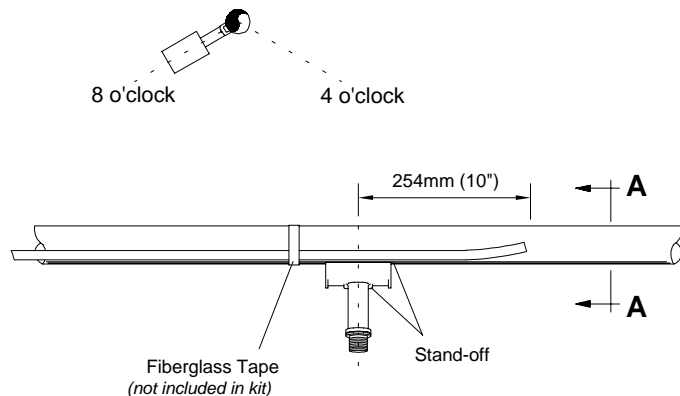

⚠ WARNING:

**Do not place pipe clamps
over the heater cable.**

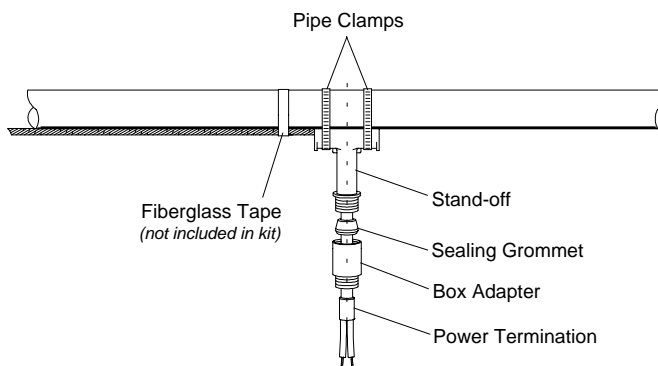

- 1 Mark pipe where stand-off will be mounted.
- 2 Push heater cable through bottom opening of stand-off.
- 3 Slide the sealing grommet over the heater cable and position inside stand-off opening:

for Braided "CB" Products:

See "Grommet Installation for Braided "CB" Products", sheet 3.

for Overjacket "J" or "JT" Products

Proceed with step 4 below.

- 4 Apply silicone around the heater cable on top of the sealing grommet and fill any voids in sealing grommet.
- 5 Slide the box adapter over the heater cable and tighten securely to stand-off.
- 6 Prepare heater cable for power termination:
for Braided "CB" Products, see sheet 3.
for Overjacket "J" or "JT" Products, see sheet 4.
- 7 Terminate heater cable, see sheet 7.

SEALING GROMMET INSTALLATION FOR BRAIDED "CB" PRODUCTS

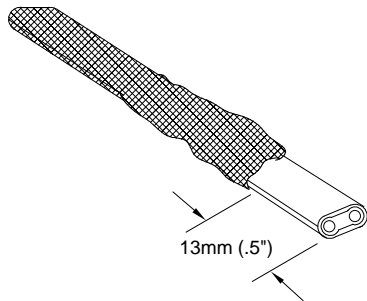

- 1 Slide braid back, allowing at least 13mm (.5") of heater cable exposed.
- 2 Cut and remove 13mm (.5") of heater cable.

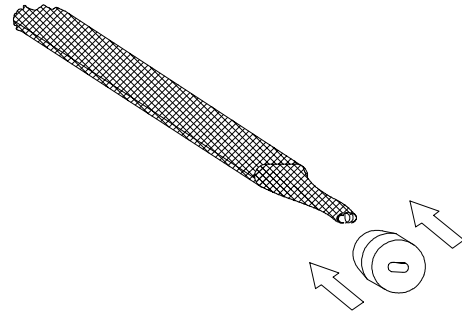

- 3 Slide braid back over heater cable and twist excess braid into a pigtail.
- 4 Slide the sealing grommet over the heater cable and position inside stand-off opening.
- 5 Continue with step 4 on sheet 2.

BRAIDED "CB" PRODUCTS

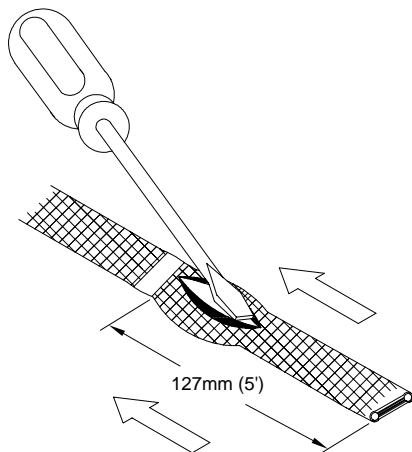

- 1 Secure cable braid with fiberglass tape.
- 2 Slide braid back 127mm (5") to create a bulge.
- 3 At the bulge, separate the braid to make an opening.

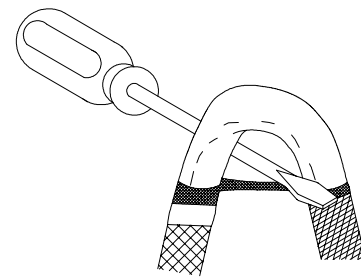

- 4 While bending the heater cable, work it through the braid opening.

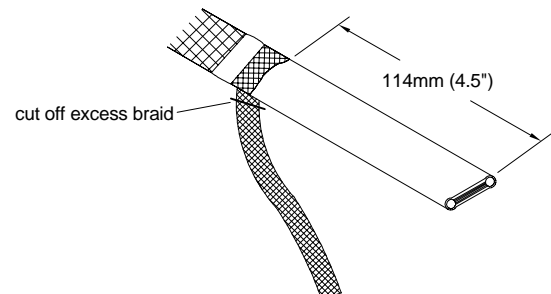

- 5 Pull the braid tight.
- 6 Cut off excess braid.
- 7 Proceed to "LT, CLT & HLT Products", sheet 5

OVERJACKET "J" or "JT" PRODUCTS

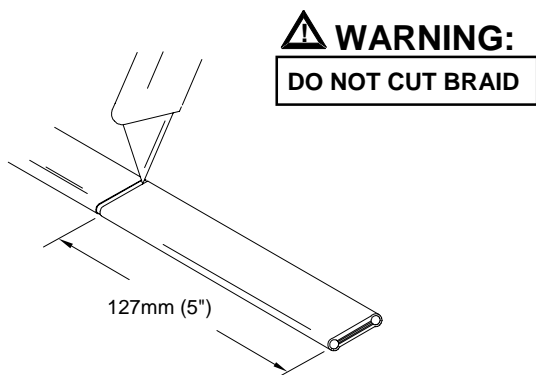

- 1 Lightly cut around cable overjacket 127mm (5") from the end. Bend cable to break the overjacket.
- 2 Lightly cut overjacket up the center between first cut mark and the cable end. Bend cable to break the overjacket.

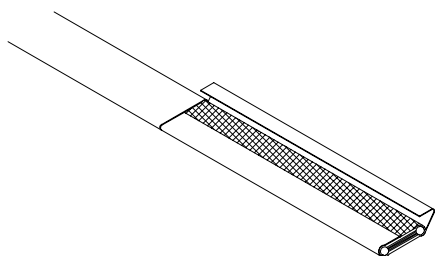

- 3 Remove overjacket from heater cable.

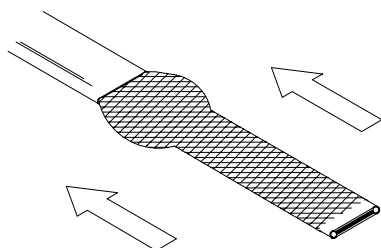

- 4 Move braid back toward the overjacket, creating a bulge.

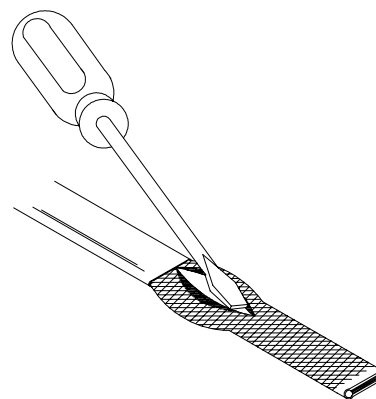

- 5 At the bulge, separate the braid to make an opening.

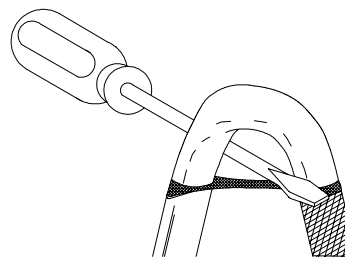

- 6 While bending the heater cable, work it through the braid opening.

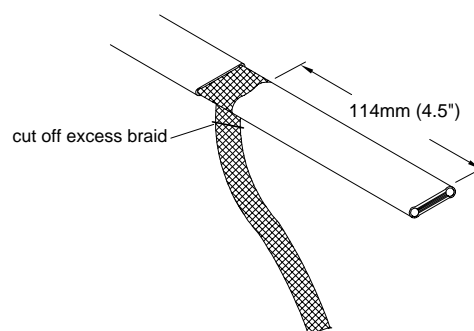

- 7 Pull the braid tight.
- 8 Cut off excess braid.
- 9 Proceed to "*LT, CLT & HLT Products*", sheet 5.

NELSON HEAT TRACING SYSTEMS

PLT-L SERIES END OF CIRCUIT LIGHT KIT

INSTALLATION INSTRUCTIONS

FOR ALL NELSON LT, CLT & HLT PRODUCTS

(See sheet 6 for an alternate stripping method for HLT products.)

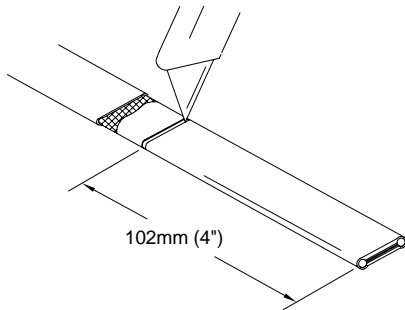

- 1 Lightly cut around cable outer jacket 102mm (4") from the end. Bend cable to break outer jacket.
- 2 Lightly cut the outer jacket up the center between the first cut mark & the cable end. Bend cable to break outer jacket.

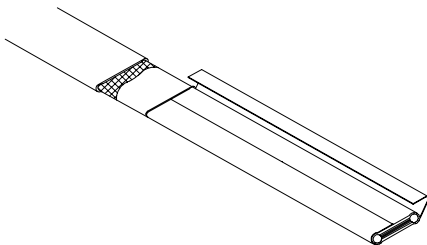

- 3 Remove the jacket from the heater cable.

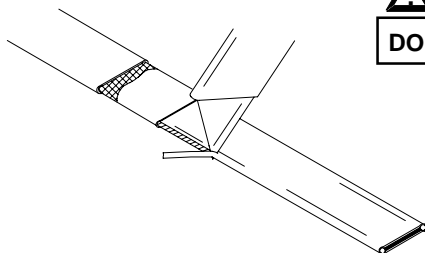

- 4 Shave the core material from the outside of each bus wire.

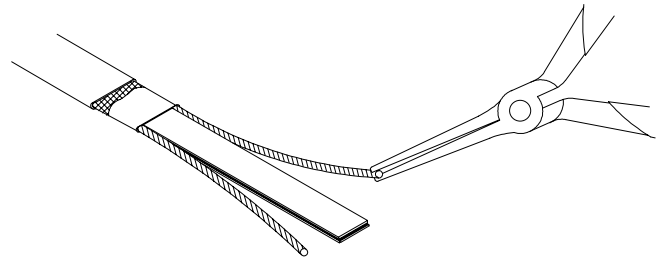

- 5 Starting at the end, pull each bus wire away from the core material.
- 6 Remove exposed core material.

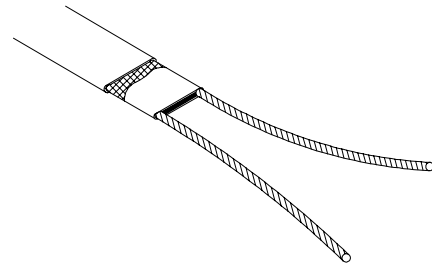

- 7 Cut 6mm (0.25") off the end of each bus wire.
- 8 Proceed to "Power Termination", sheet 7.

⚠ WARNING:
DO NOT CUT BUS WIRES

HLT PRODUCTS ALTERNATE STRIPPING METHOD

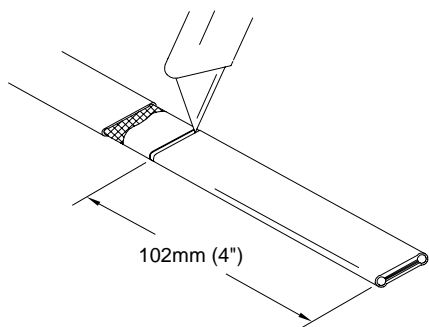

- 1 Lightly cut around cable outer jacket 102mm (4") from the end. Bend cable to break outer jacket.
- 2 Lightly cut the outer jacket up the center between the first cut mark & the cable end. Bend cable to break outer jacket.

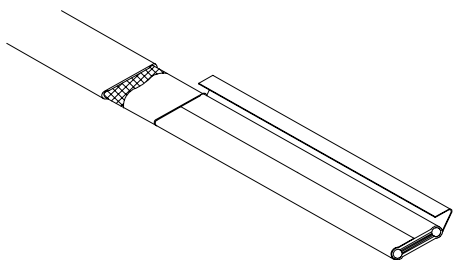

- 3 Remove the jacket from the heater cable.

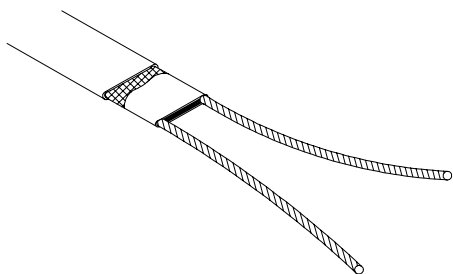

- 4 Make a cut inside each bus wire.

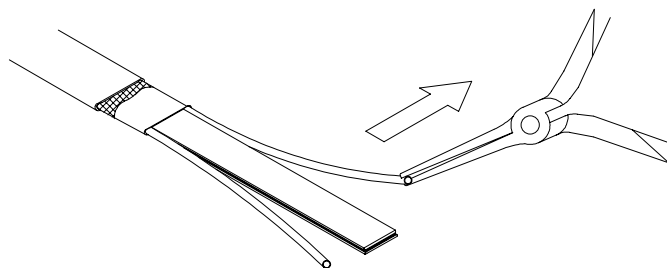

- 5 Starting at the end, in the same plane as the cable, pull each bus wire away from the core material.

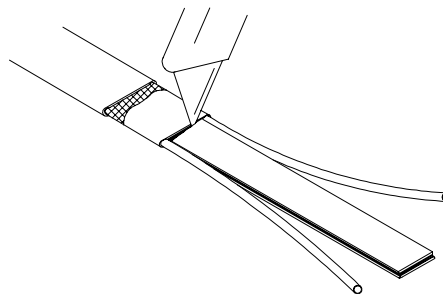

- 6 Remove the exposed core material.

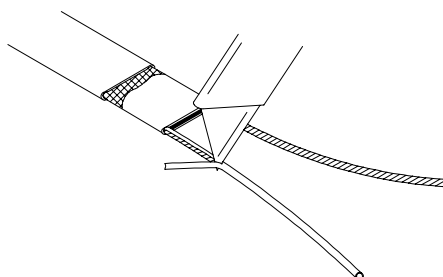

- 7 Remove the remaining core material off the outside of each bus wire.
- 8 Cut 6mm (0.25") off the end of each bus wire.
- 9 Proceed to "Power Termination", sheet 7.

POWER TERMINATION

⚠ WARNING:

Bus wires must not touch or cross while inserting into power termination.

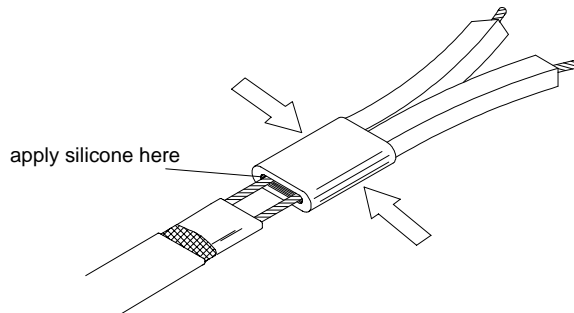

- 1 Insert bus wires into power termination.
- 2 Squeeze power termination opening and fill with silicone.

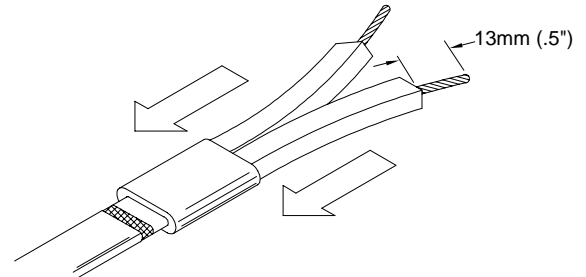

- 3 Push power termination to overlap jacket.
- 4 The silicone will set up in about 30 minutes with a complete cure after 24 hours.
- 5 Proceed to “*Electrical Connection*”, sheet 8.

ELECTRICAL CONNECTION

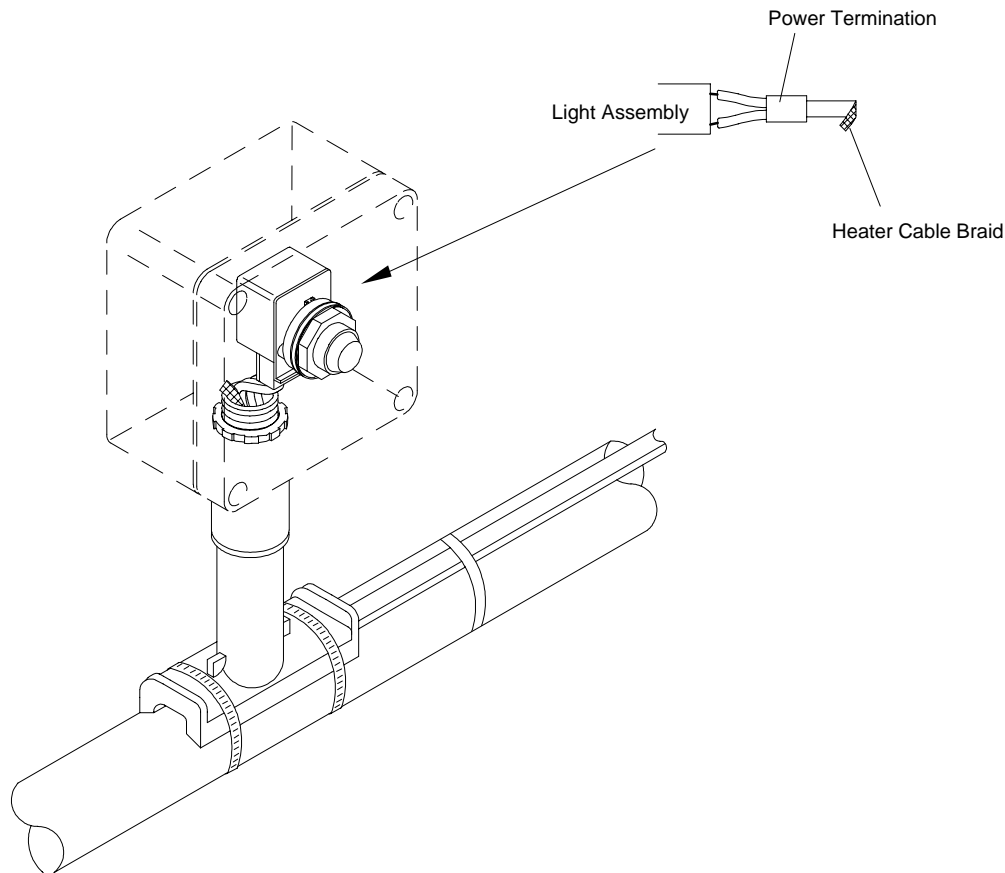

Note: This detail shows Overjacket “J” or “JT” Products only. For Braided “CB” Products see diagram on sheet 1.

- ❶ Place gasket onto the box adapter.
- ❷ Position junction box onto the box adapter and secure it with the conduit locknut.
- ❸ Place the two black compensating gaskets onto the light assembly base.
- ❹ Insert power wires into screw connection of light assembly.
- ❺ Place the box cover onto the light assembly then install the clear trim washer and secure it with the ring nut.
- ❻ Secure the box cover onto junction box.